



Generative Information Retrieval

Yubao Tang^{a,b}, Ruqing Zhang^{a,b}, Jiafeng Guo^{a,b} and Maarten de Rijke^c

<https://sigir-ap2023-generative-ir.github.io/>

January 11, 2024

^a Institute of Computing Technology, Chinese Academy of Sciences

^b University of Chinese Academy of Sciences

^c University of Amsterdam

About presenters

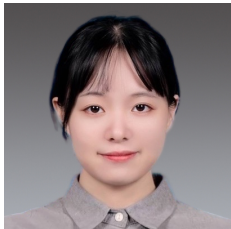

Yubao Tang
Phd student
@ICT, CAS



Ruqing Zhang
Faculty
@ICT, CAS



Jiafeng Guo
Faculty
@ICT, CAS



Maarten de Rijke
Faculty
@UvA

Information retrieval

Information retrieval (IR) is the activity of obtaining information system resources that are relevant to an information need from a collection of those resources.



Given: User query (keywords, question, image, ...)

Rank: Information objects (passages, documents, images, products, ...)

Ordered by: Relevance scores

Core pipelined paradigm: Index-Retrieval-Ranking

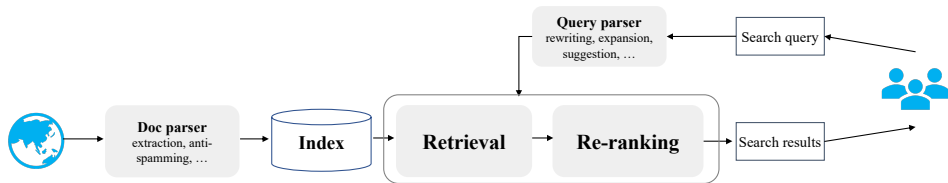

- Index: Build an index for each document in the entire corpus
- Retriever: Find an initial set of candidate documents for a query
- Re-ranker: Determine the relevance degree of each candidate

Index-Retrieval-Ranking: Disadvantages

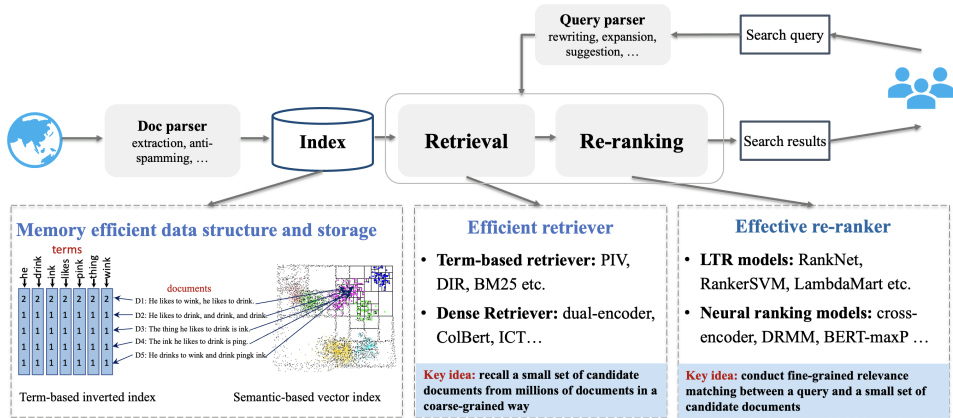

- **Effectiveness:** Heterogeneous ranking components are usually difficult to be optimized in an end-to-end way towards the global objective

Index-Retrieval-Ranking: Disadvantages

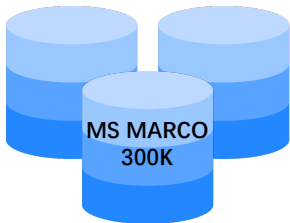

Big storage

GTR (Dense retrieval)
Memory size **1430MB**

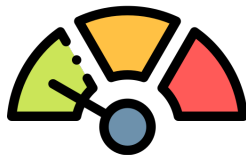

Slow inference speed

GTR (Dense retrieval)
Online latency **1.97s**

- **Efficiency:** A large document index is needed to search over the corpus, leading to significant memory consumption and computational overhead

What if we replaced the pipelined architecture with a single consolidated model that efficiently and effectively encodes all of the information contained in the corpus?

Opinion paper: A single model for IR

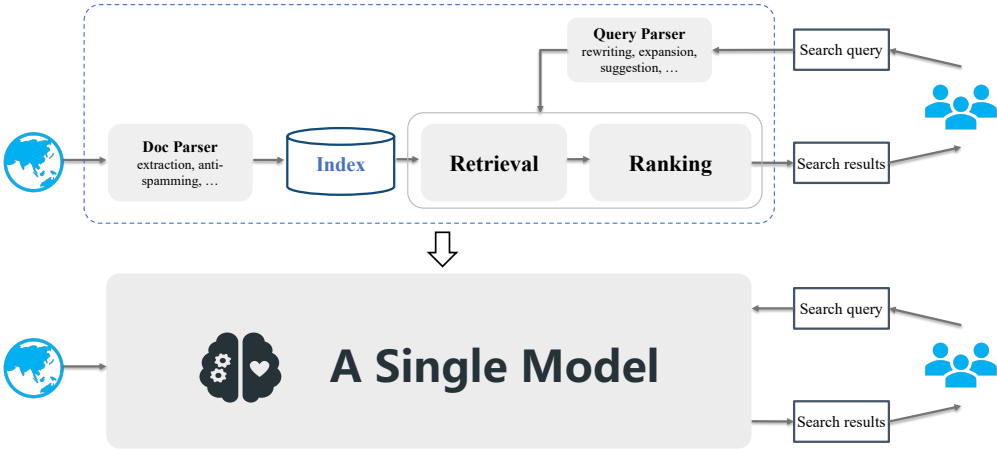

Generative language models

Publicly Available

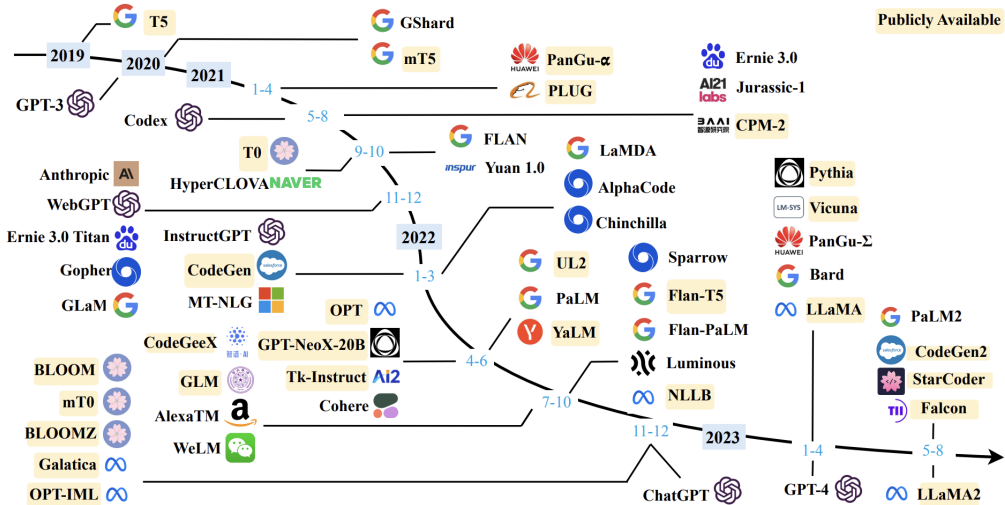

Image source: [Zhao et al., 2023]

Two families of generative retrieval

- **Closed-book**: The language model is the **only source** of knowledge leveraged during generation, e.g.,
 - Capturing document ids in the language models
 - Language models as retrieval agents via prompting
- **Open-book**: The language model can draw on **external memory** prior to, during and after generation, e.g.,
 - Retrieve-augmented generation of answers
 - Tool-augmented generation of answers

Two families of generative retrieval

- **Closed-book**: The language model is the **only source** of knowledge leveraged during generation, e.g.,
 - ✓ ■ Capturing document ids in the language models
 - Language models as retrieval agents via prompting
- **Open-book**: The language model can draw on **external memory** prior to, during and after generation, e.g.,
 - Retrieve-augmented generation of answers
 - Tool-augmented generation of answers

Closed-book generative retrieval

The IR task can be formulated as a **sequence-to-sequence (Seq2Seq)** generation problem

Closed-book generative retrieval

The IR task can be formulated as a **sequence-to-sequence (Seq2Seq)** generation problem

- **Input:** A sequence of query words
- **Output:** A sequence of document identifiers

Neural IR models: Discriminative vs. Generative

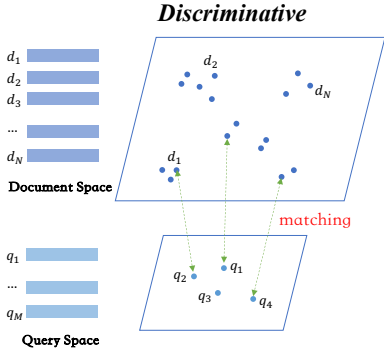

$$p(R = 1|q, d) \approx \dots \approx \operatorname{argmax} s(\vec{q}, \vec{d})$$

(probabilistic ranking principle)

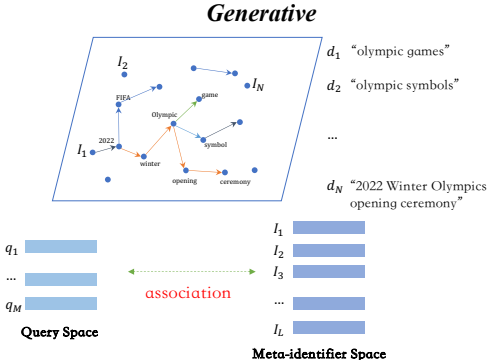

$$p(q|d) \approx p(\operatorname{docID}|q) = \operatorname{argmax} p((I_1, \dots, I_k)|q)$$

(query likelihood)

Why generative retrieval?

Heterogeneous objectives

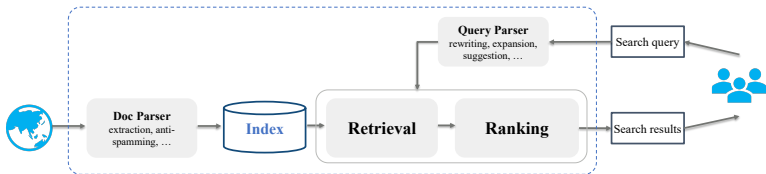

V/S

A global objective

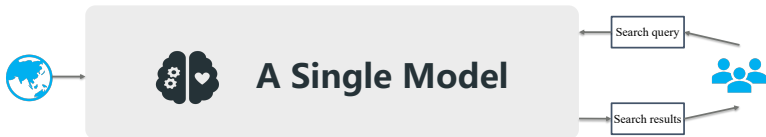

- **Effectiveness:** Knowledge of all documents in corpus is encoded into model parameters, which can be optimized directly in an end-to-end manner

Why generative retrieval?

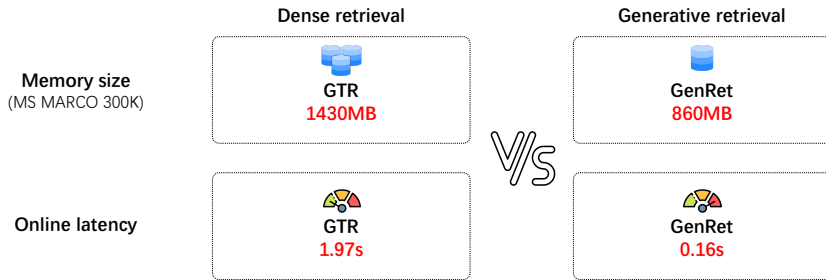

- **Efficiency:** Main memory computation of GR is the storage of document identifiers and model parameters
- Heavy retrieval process is replaced with a light generative process over the vocabulary of identifiers

Statistics of related publications

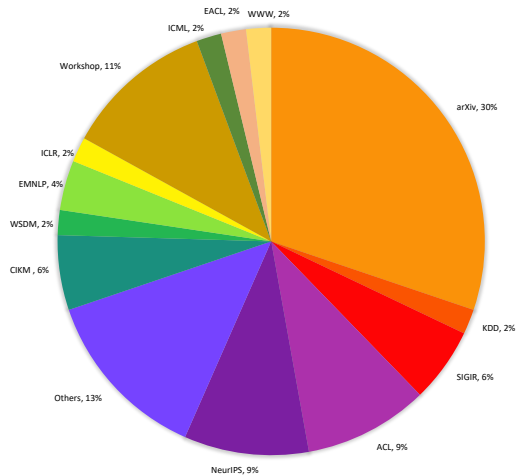
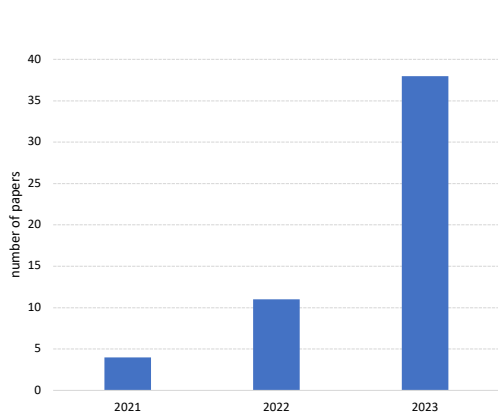

The data statistics cover up to November 20, 2023.

Goals of the tutorial

- We will cover key developments on generative information retrieval (mostly 2021–2023)
 - **Problem definitions**
 - **Docid design**
 - **Training approaches**
 - **Inference strategies**
 - **Applications**

Goals of the tutorial

- We will cover key developments on generative information retrieval (mostly 2021–2023)
 - **Problem definitions**
 - **Docid design**
 - **Training approaches**
 - **Inference strategies**
 - **Applications**
- We are still far from understanding how to best develop generative IR architecture compared to traditional pipelined IR architecture:
 - Taxonomies of existing research and key insights
 - Our perspectives on the **current challenges & future directions**

Section 2: Definitions & Preliminaries

Generative retrieval: Definition

Generative retrieval (GR) aims to directly generate the **identifiers** of information resources (e.g., docids) that are relevant to an information need (e.g., an input query) in **an autoregressive fashion**

Generative retrieval: Definition

GR usually exploits a Seq2Seq encoder-decoder architecture to generate a ranked list of docids for an input query, in an autoregressive fashion

Two basic operations in GR

- **Indexing**: To **memorize information about each document**, a GR model should learn to associate the content of each document with its corresponding docid

Two basic operations in GR

- **Indexing**: To **memorize information about each document**, a GR model should learn to associate the content of each document with its corresponding docid
- **Retrieval**: Given an input query, a GR model should **return a ranked list of candidate docids** by autoregressively generating the docid string

Indexing: Formulation

Given:

- A corpus of documents D ;
- A corresponding docid set I_D ;

Indexing: Formulation

Given:

- A corpus of documents D ;
- A corresponding docid set I_D ;

The indexing task directly takes each original document $d \in D$ as input and generates its docid $id \in I_D$ as output in a straightforward Seq2Seq fashion, i.e.,

$$\mathcal{L}_{Indexing}(D, I_D; \theta) = - \sum_{d \in D} \log P(id | d; \theta),$$

where θ denotes the model parameters, and $P(id | d; \theta)$ is the likelihood of each docid id given the document d

Retrieval: Formulation

Given:

- A query set Q ;
- A set of relevant docids I_Q ;

Retrieval: Formulation

Given:

- A **query set** Q ;
- A set of **relevant docids** I_Q ;

The retrieval task aims to generate a ranked list of relevant docids $id^q \in I_Q$ in response to a query $q \in Q$ with the indexed information, i.e.,

$$\mathcal{L}_{\text{Retrieval}}(Q, I_Q; \theta) = - \sum_{q \in Q} \sum_{id^q \in I_Q} \log P(id^q | q; \theta),$$

where $P(id^q | q; \theta)$ is the likelihood of each relevant docid id^q given the query q

Following the above two basic operations, i.e., indexing and retrieval, a single model can be optimized directly in **an end-to-end manner** towards **a global objective**,

Following the above two basic operations, i.e., indexing and retrieval, a single model can be optimized directly in **an end-to-end manner** towards **a global objective**,

$$\mathcal{L}_{Global}(Q, D, I_D, I_Q; \theta) = \mathcal{L}_{Indexing}(D, I_D; \theta) + \mathcal{L}_{Retrieval}(Q, I_Q; \theta)$$

Training: An example

Retrieval

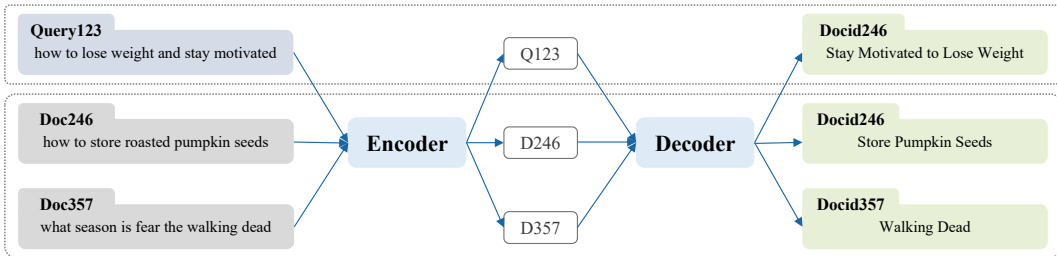

Indexing

Joint learning the indexing and retrieval tasks

- Once such a GR model is learned, it can be used to generate candidate docids for a test query q_t , all **within a single, unified model**,

$$w_t = GR_{\theta}(q_t, w_0, w_1, \dots, w_{t-1}),$$

where w_t is the t -th token in the docid string and the generation stops when decoding a special EOS token

- Once such a GR model is learned, it can be used to generate candidate docids for a test query q_t , all **within a single, unified model**,

$$w_t = GR_{\theta}(q_t, w_0, w_1, \dots, w_{t-1}),$$

where w_t is the t -th token in the docid string and the generation stops when decoding a special EOS token

- The docids generated with the **top- K highest** likelihood (joint probability of generated tokens within a docid) form a ranking list in descending order

Research questions (1): Docid design

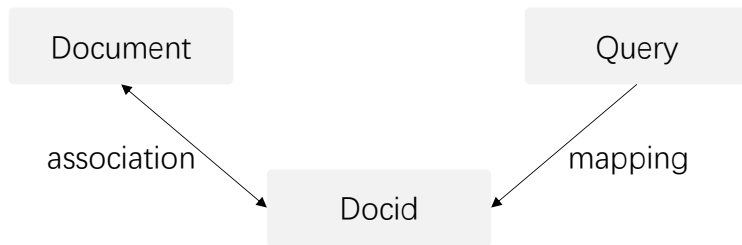

Unfortunately, there is no natural identifier for each document!

Research questions (1): Docid design

Traditional information retrieval

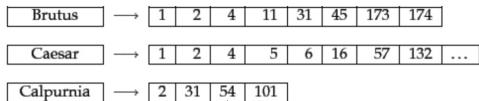

Document features

As an entry

Generative retrieval

Docid: xx xxx x

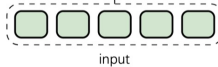
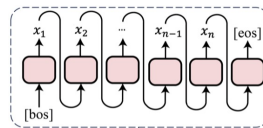

input

For generation

Research questions (1): Docid design

Traditional information retrieval

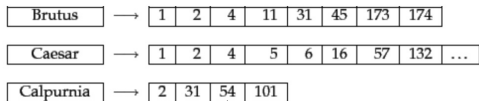

Document features

As an entry

Generative retrieval

Docid: xx xxx x

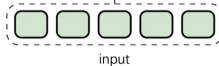
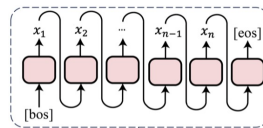

For generation

How to design docids for documents?

- Shall we use randomized numbers or codes as docids?

Challenges of docid design

- **Shall we use randomized numbers or codes as docids?**
- **If not, how to obtain proper identifiers for documents?**
 - Titles, URLs or ?

- **Shall we use randomized numbers or codes as docids?**
- **If not, how to obtain proper identifiers for documents?**
 - Titles, URLs or ?
- **Would the choices of different docids affect the model performance (e.g., effectiveness, capacity, etc.)?**
 - Long (e.g., 728 hash code) vs. Short docids (e.g., n-grams)
 - Single (e.g., title or URL) vs. Multiple docids (e.g., multiple keywords)

Challenges of docid design

- **Shall we use randomized numbers or codes as docids?**
- **If not, how to obtain proper identifiers for documents?**
 - Titles, URLs or ?
- **Would the choices of different docids affect the model performance (e.g., effectiveness, capacity, etc.)?**
 - Long (e.g., 728 hash code) vs. Short docids (e.g., n-grams)
 - Single (e.g., title or URL) vs. Multiple docids (e.g., multiple keywords)

We will tackle these questions in Section 3!

Research questions (2): Training approaches

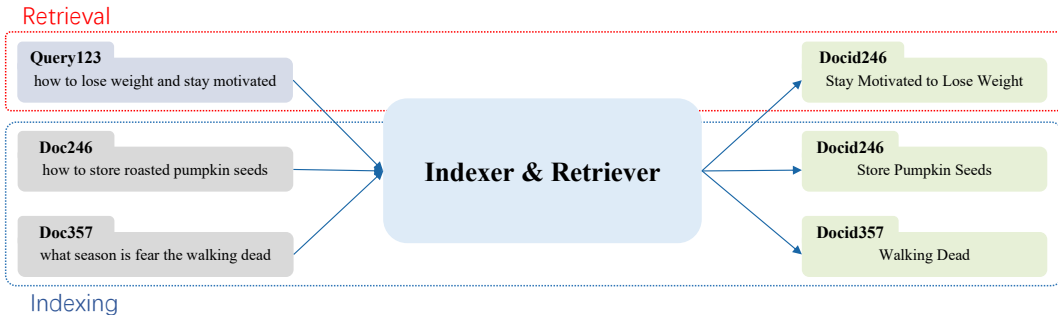

Joint learning process of the indexing and retrieval tasks

- **How to memorize the whole corpus effectively and efficiently?**
 - Rich information in documents
 - Limited labeled data

Challenges of training approaches

- **How to memorize the whole corpus effectively and efficiently?**
 - Rich information in documents
 - Limited labeled data
- **How to learn heterogeneous tasks well within a single model?**
 - Different data distributions
 - Different optimization objectives

- **How to memorize the whole corpus effectively and efficiently?**
 - Rich information in documents
 - Limited labeled data
- **How to learn heterogeneous tasks well within a single model?**
 - Different data distributions
 - Different optimization objectives
- **How to handle a dynamically evolving document collection?**
 - Internal index: model parameters
 - High computational costs: re-training from scratch every time the underlying corpus is updated

Challenges of training approaches

- **How to memorize the whole corpus effectively and efficiently?**
 - Rich information in documents
 - Limited labeled data
- **How to learn heterogeneous tasks well within a single model?**
 - Different data distributions
 - Different optimization objectives
- **How to handle a dynamically evolving document collection?**
 - Internal index: model parameters
 - High computational costs: re-training from scratch every time the underlying corpus is updated

We will tackle these questions in Section 4!

Research questions (3): Inference strategies

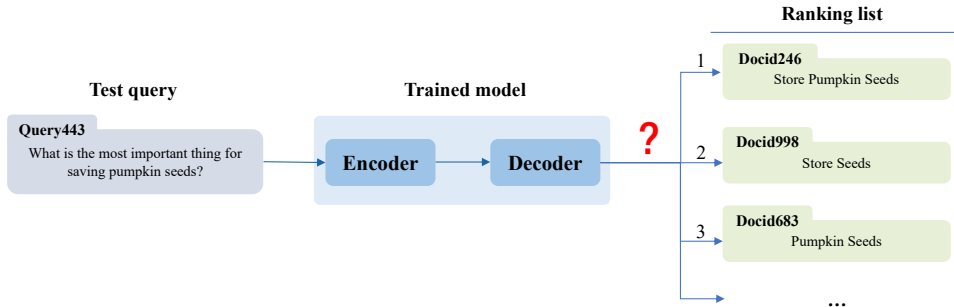

The generation process is different from general language generation

- **How to generate valid docids?**
 - Limited docids vs. free generation

- **How to generate valid docids?**
 - Limited docids vs. free generation
- **How to organize the docids for large scale corpus?**
 - Data structure for docids over millions of documents

- **How to generate valid docids?**
 - Limited docids vs. free generation
- **How to organize the docids for large scale corpus?**
 - Data structure for docids over millions of documents
- **How to generate a ranked list of docids for a query?**
 - One-by-one generation: likelihood probabilities
 - One-time generation: directly decoding a sequence of docids

- **How to generate valid docids?**
 - Limited docids vs. free generation
- **How to organize the docids for large scale corpus?**
 - Data structure for docids over millions of documents
- **How to generate a ranked list of docids for a query?**
 - One-by-one generation: likelihood probabilities
 - One-time generation: directly decoding a sequence of docids

We will tackle these questions in Section 5!

Research questions (4): Applications

How to employ generative retrieval models in different downstream tasks?

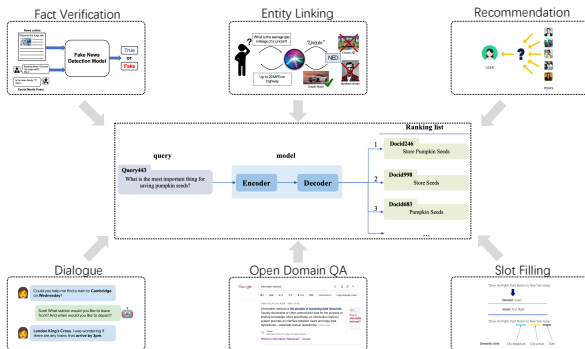

Research questions (4): Applications

How to employ generative retrieval models in different downstream tasks?

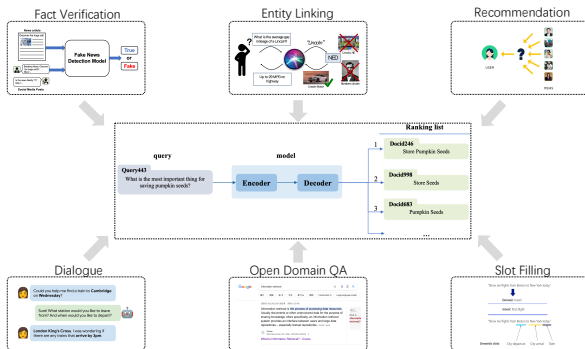

We will tackle this question in Section 6!

Section 3: Docid design

- Shall we use randomize numbers as the docids?
- If not, how to construct proper docids for the documents?
- Would the choices of different docids affect the model performance (effectiveness, capacity, etc.)?

Categorization of docids

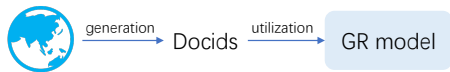

- Pre-defined static docids

Categorization of docids

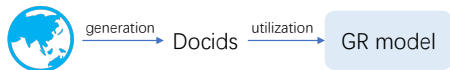

- Pre-defined static docids

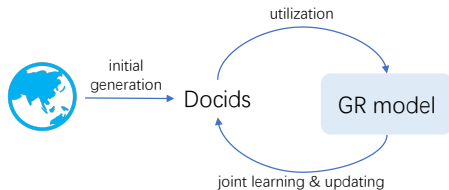

- Learnable docids

Roadmap of pre-defined static docids

Number-based
docids

Roadmap of pre-defined static docids

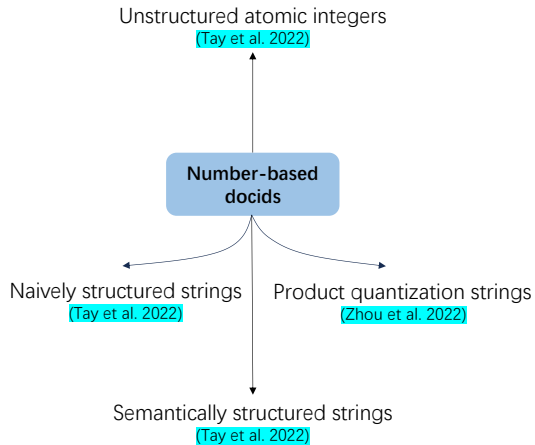

Roadmap of pre-defined static docids

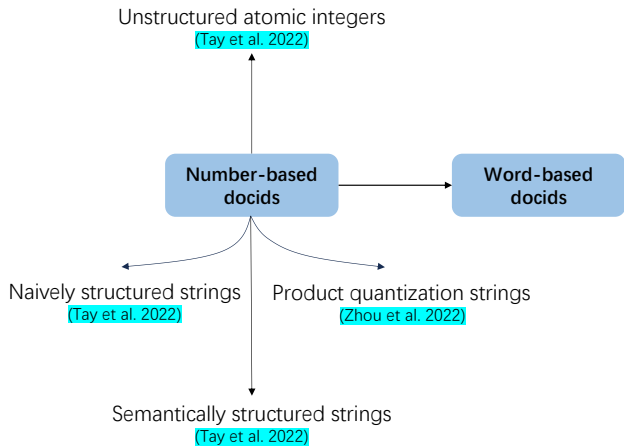

Roadmap of pre-defined static docids

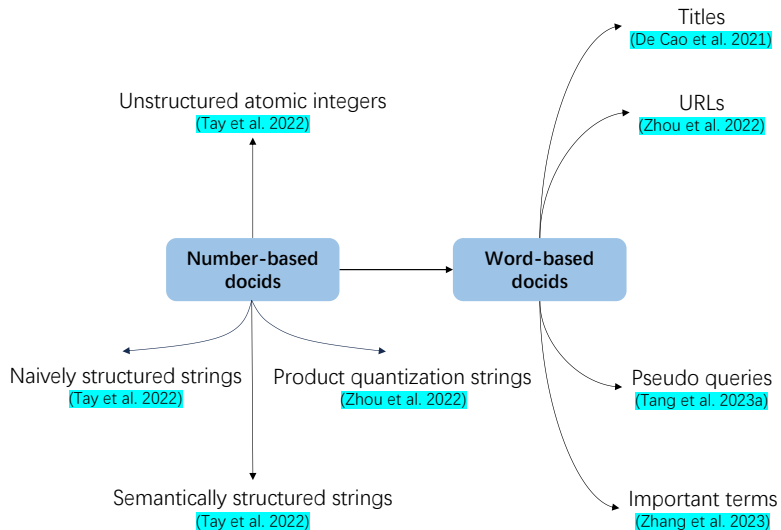

Roadmap of pre-defined static docids

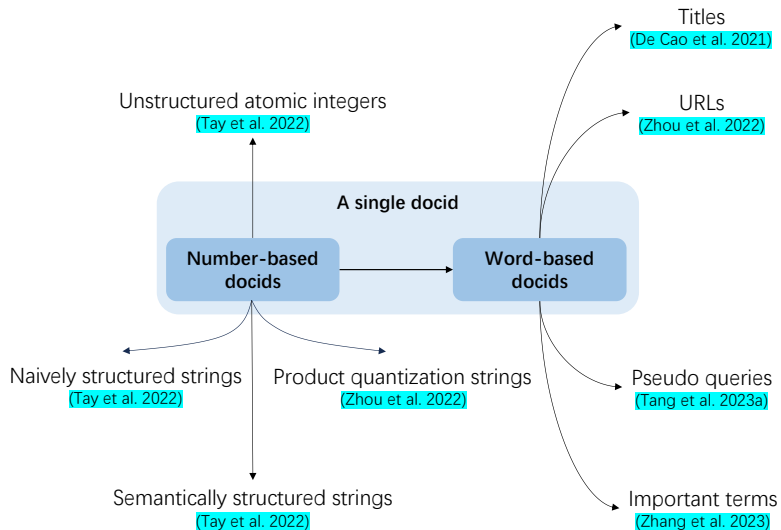

Roadmap of pre-defined static docids

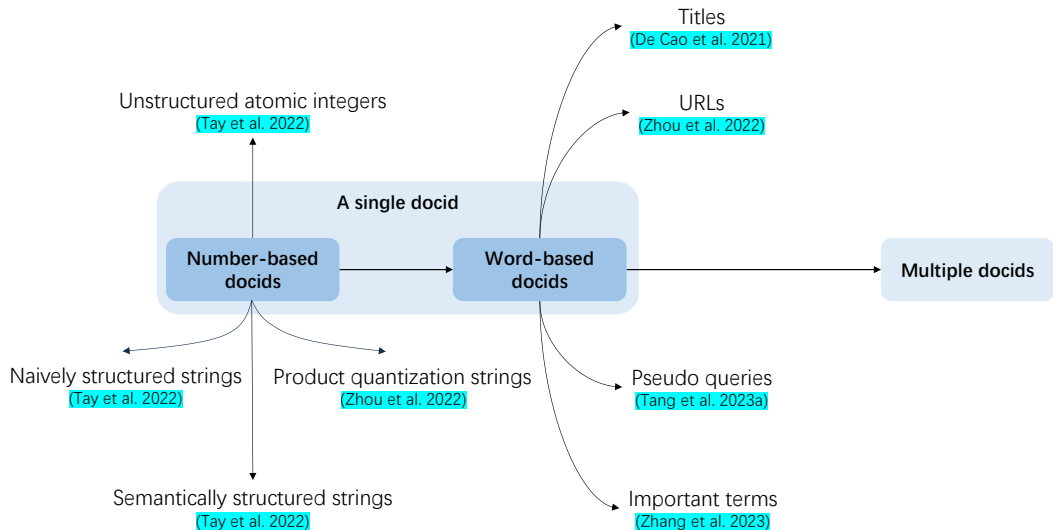

Roadmap of pre-defined static docids

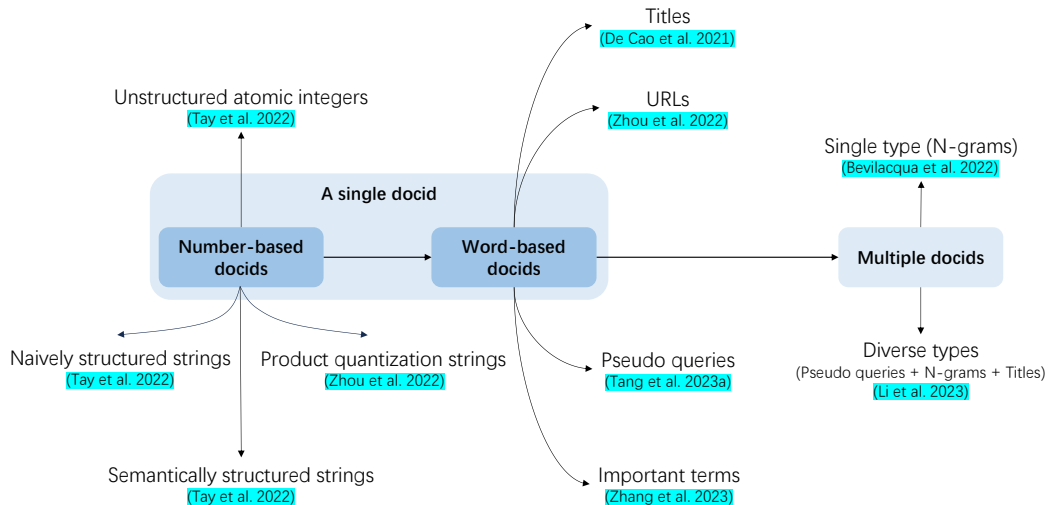

A single docid: Number-based

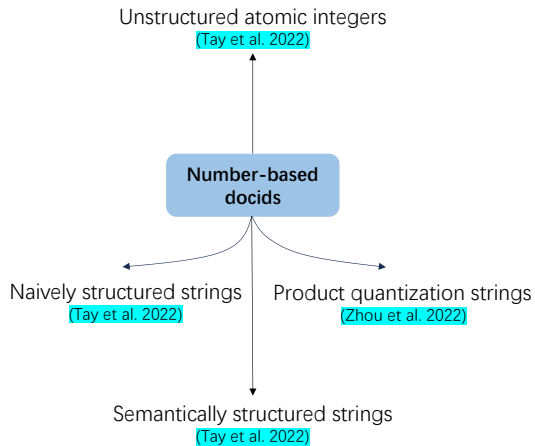



Number-based: Unstructured atomic integers

- An arbitrary (and possibly random) unique integer identifier

Number-based: Unstructured atomic integers

- An arbitrary (and possibly random) unique integer identifier

Corpus	Docids
	0
	1
	2
...	...

Number-based: Unstructured atomic integers

- **Decoding formulation:** learn a probability distribution over the docid embeddings, i.e., emitting one logit for each unique docid

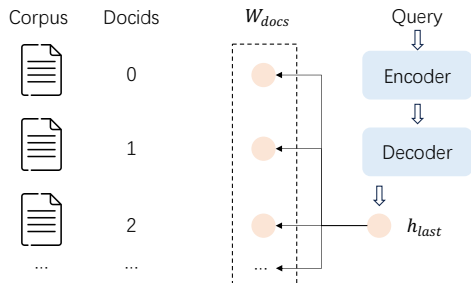

$$O = \text{Softmax}([W_{docs}]^T h_{last}),$$

where $[W_{docs}]$ is the document embedding matrix, and h_{last} is the last layer's hidden state of the decoder

Unstructured atomic integers and subsequent work

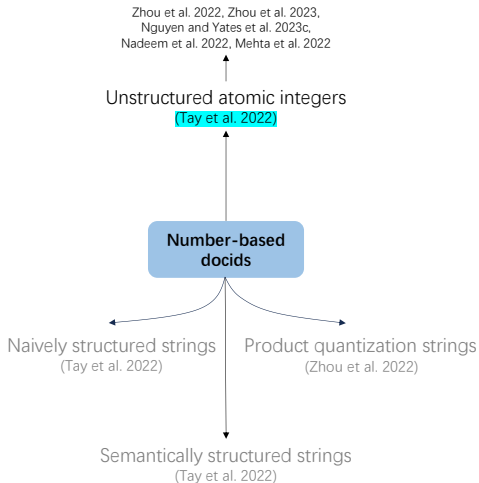

Unstructured atomic integers and subsequent work

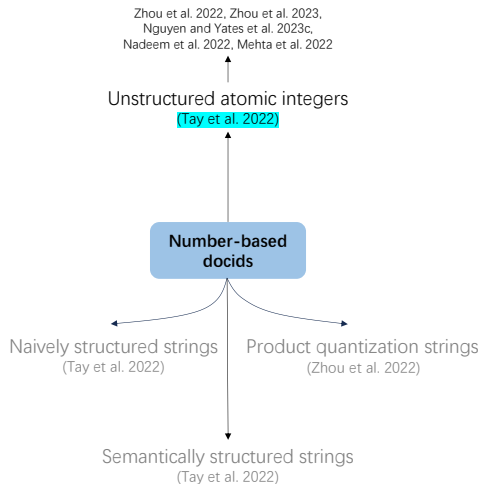

Easy to build: analogous to the output layer in standard language model



The need to learn embeddings for each individual docid

Unstructured atomic integers: obvious constraints



The need to learn embeddings for each individual docid



The need for the large softmax output space

Unstructured atomic integers: obvious constraints



The need to learn embeddings for each individual docid



The need for the large softmax output space

It is challenging to be used on large corpora!

Number-based: Naively structured strings

- Treat arbitrary unique integers as tokenizable strings

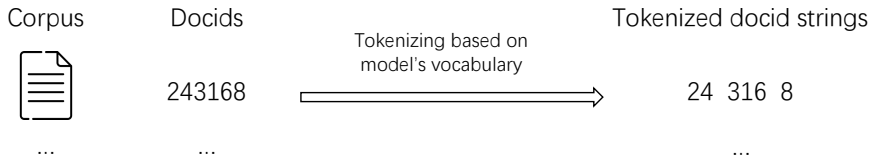

Number-based: Naively structured strings

- **Decoding formulation:** Generating a docid string in a token-by-token manner

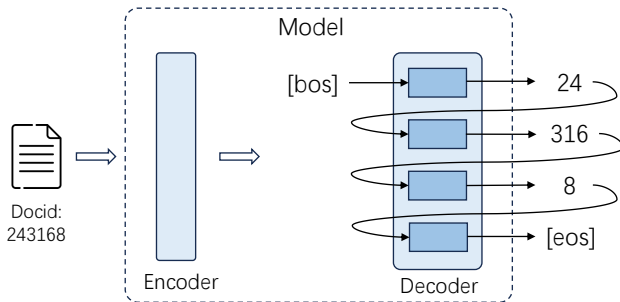

Naively structured strings and subsequent work

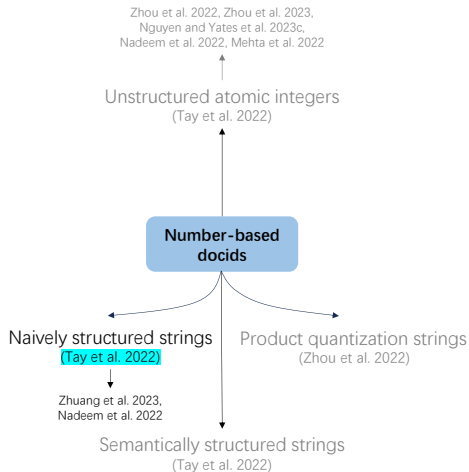

Naively structured strings and subsequent work

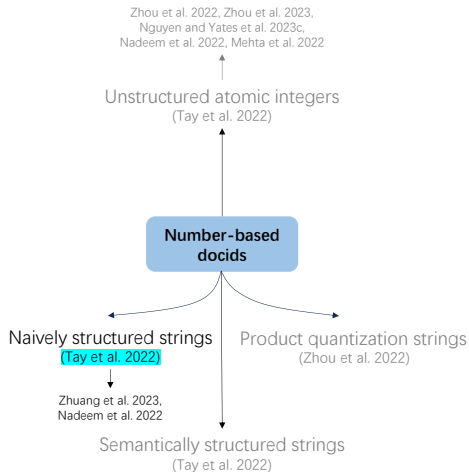

Such a way frees the limitation for the **corpus size** that comes with unstructured atomic docid

Naively structured strings: obvious constraints



Identifiers are assigned in an **arbitrary manner**

Naively structured strings: obvious constraints



Identifiers are assigned in an **arbitrary manner**



The docid space **lacks semantic structure**

Number-based: Semantically structured strings

Properties:

- The docid should capture **some information about the semantics** of its associated document

Number-based: Semantically structured strings

Properties:

- The docid should capture **some information about the semantics** of its associated document
- The docid should be structured in a way that **the search space is effectively reduced** after each decoding step

Number-based: Semantically structured strings

Properties:

- The docid should capture **some information about the semantics** of its associated document
- The docid should be structured in a way that **the search space is effectively reduced** after each decoding step



Semantically similar documents share identifier prefixes

Number-based: Semantically structured strings

- A hierarchical clustering algorithm over document embeddings to induce a decimal tree

Number-based: Semantically structured strings

- A hierarchical clustering algorithm over document embeddings to induce a decimal tree

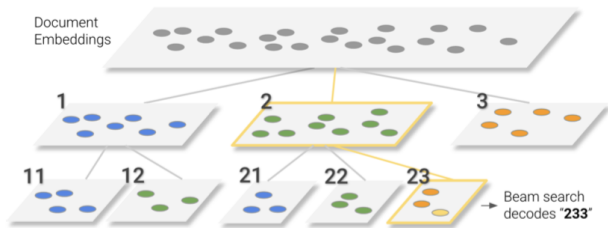

Semantically structured strings and subsequent work

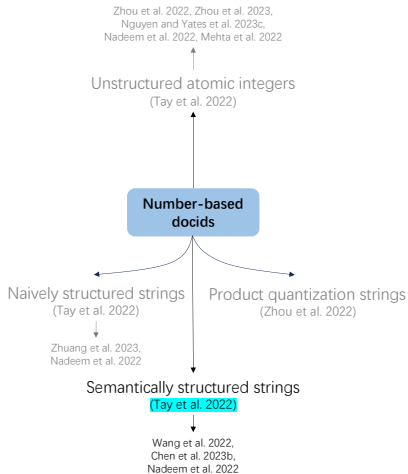

Semantically structured strings and subsequent work

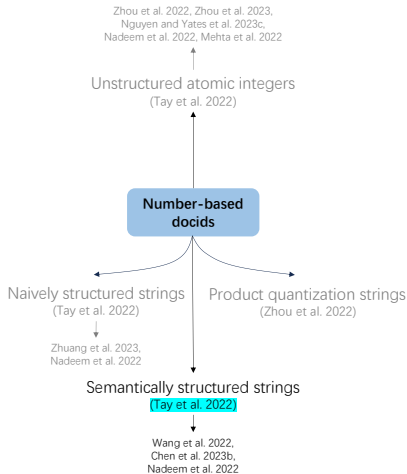

The document semantics can be incorporated in the decoding process

It is not limited by the size of the corpus

Performance comparisons [Tay et al., 2022]

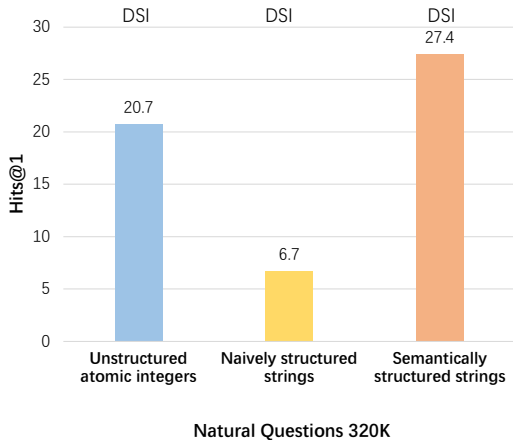

- Backbone: T5-base
- Observations: imbuing the docid space with semantic structure can lead to better retrieval capabilities

Performance comparisons [Tay et al., 2022]

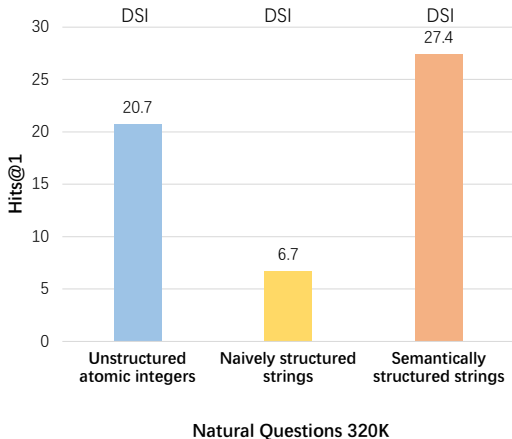

- Backbone: T5-base
- Observations: imbuing the docid space with semantic structure can lead to better retrieval capabilities

This is only about "identifiers"

Later sections will discuss the performance compared to traditional IR models

Number-based: Product quantization strings

- Product quantization (PQ) is a technique used for vector compression

Number-based: Product quantization strings

- Product quantization (PQ) is a technique used for vector compression
- An original vector is represented by a short code composed of its subspace quantization indices

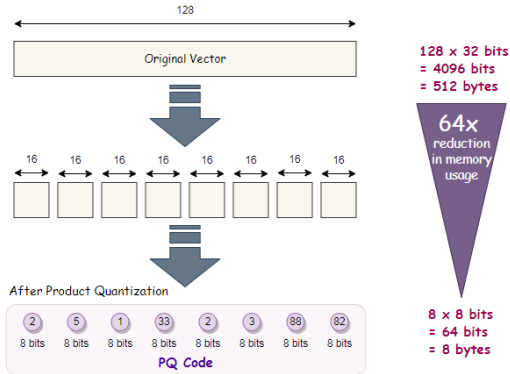

Number-based: Product quantization strings

Given all D -dimensional embedding vectors of documents [Zhou et al., 2022],

Number-based: Product quantization strings

Given all D -dimensional embedding vectors of documents [Zhou et al., 2022],

- Divide the D -dimensional space into m groups

Number-based: Product quantization strings

Given all D -dimensional embedding vectors of documents [Zhou et al., 2022],

- Divide the D -dimensional space into m groups
- Perform K -means clustering on each group to obtain k cluster centers

Number-based: Product quantization strings

Given all D -dimensional embedding vectors of documents [Zhou et al., 2022],

- Divide the D -dimensional space into m groups
- Perform K -means clustering on each group to obtain k cluster centers
- Each embedding vector can be represented as a set of m cluster identifiers. For each document d , its product quantization string identifier id_{PQ} can be defined,

$$id_{PQ} = PQ(Encoder(d)),$$

where $Encoder(\cdot)$ can be implemented by different language models

Product quantization strings and subsequent work

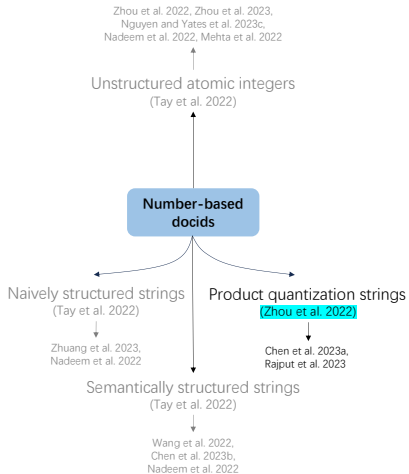

Product quantization strings and subsequent work

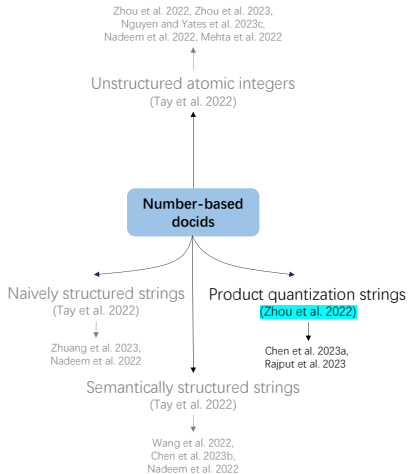

Preserving dense vector semantics in a smaller space

Capturing local semantic information

Performance comparisons

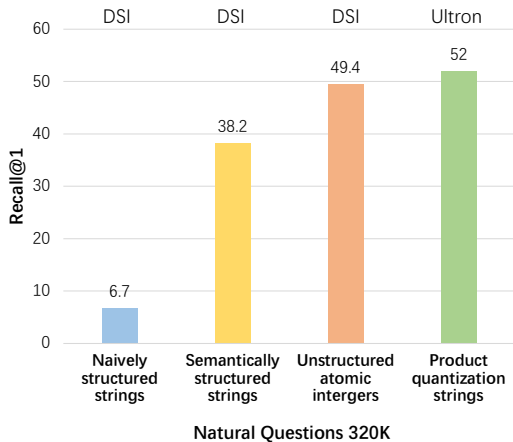

- Backbone: T5-base
- Observations: **Product quantization string identifiers** improves over structured semantic identifiers



Docids based on integers are easy to build

Number-based docids: Summary



Docids based on integers are easy to build



Unstructured atomic integers and naively/semantically structured strings can maintain **uniqueness**

Number-based docids: Summary



Docids based on integers are easy to build







Unstructured atomic integers and naively/semantically structured strings can maintain **uniqueness**



Number-based docids are composed of **unreadable numbers**

Number-based docids: Summary

-  Docids based on integers are easy to build
-  Unstructured atomic integers and naively/semantically structured strings can maintain **uniqueness**
-  Number-based docids are composed of **unreadable numbers**
-  It is challenging to **interpret** the model's understanding of the corpus

A single docid: Word-based

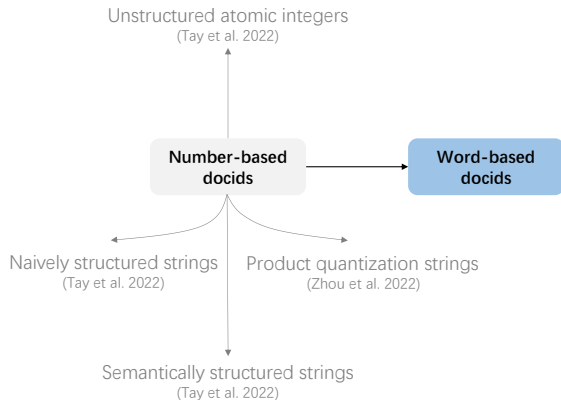

A single docid: Word-based

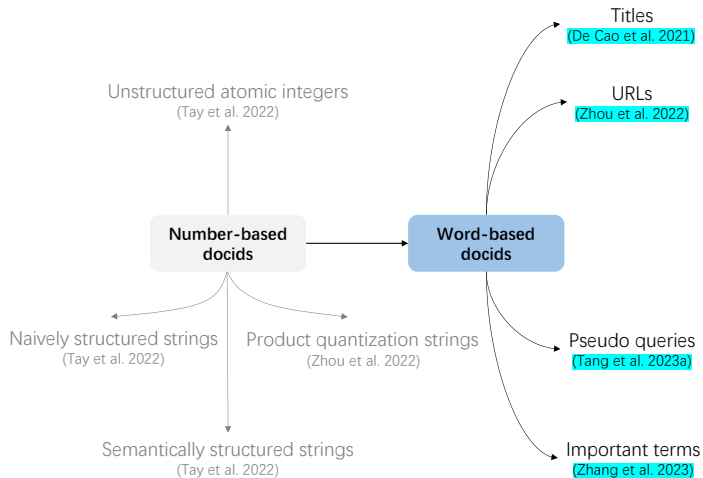

The fundamental inspiration

- The query is usually keyword-based **natural language**, which can be challenging to map into a **numeric string**, while mapping it to words would be more intuitive

A single docid: Word-based

The fundamental inspiration

- The query is usually keyword-based **natural language**, which can be challenging to map into a **numeric string**, while mapping it to words would be more intuitive
- Elaboration Strategies in human learning encoding and recall for humans: natural language vs. integer-based strings

Word-based: Titles

- Document titles: be able to summarize the main content

- Document titles: be able to summarize the main content

Information retrieval Decoding target

Article [Talk](#)

From Wikipedia, the free encyclopedia

Information retrieval (IR) in [computing](#) and [information science](#) is the process of obtaining [information system](#) resources that are relevant to an information need from a collection of those resources. Searches can be based on [full-text](#) or other content-based indexing. Information retrieval is the [science](#)^[1] of searching for information in a document, searching for documents themselves, and also searching for the [metadata](#) that describes data, and for [databases](#) of texts, images or sounds.

Automated information retrieval systems are used to reduce what has been called [information overload](#). An IR system is a software system that provides access to books, journals and other documents; it also stores and manages those documents. [Web search engines](#) are the most visible IR applications.

Chiamaka Nnadozie's father didn't want her to play soccer. Nigerian star defied him and rewrote the record books Decoding target

By Michael Johnston and [Amanda Davies](#), CNN

🕒 5 minute read · Updated 10:06 AM EDT, Wed November 1, 2023

(CNN) — It wasn't always plain sailing for Paris FC and Nigerian goalkeeper, Chiamaka Nnadozie, throughout her now-flourishing career.

Growing up in a family of boys and men – who had all tried their hand at going professional – Nnadozie's ambition to follow suit wasn't greeted with unyielding enthusiasm. Quite the opposite.

"It wasn't very good from my family. They never let me play, especially my dad," the 22-year-old told CNN's Amanda Davies.

"Whenever I went to play soccer, he would always tell me: 'Girls don't play football. Look at me. I played football, I didn't make it. Your brother, he played, he didn't make it. Your cousin played, he didn't make it. So why do you want to choose this? Why don't you want to go to school or maybe do some other things?'" Nnadozie recollected.

Titles and subsequent work

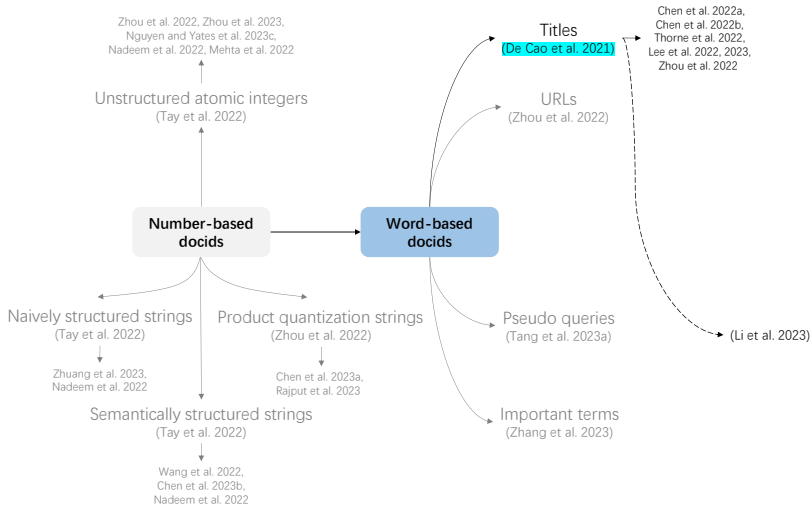



Depending on certain special document metadata

Titles: Obvious constraints



Depending on certain special document metadata



The titles may be duplicated (i.e., web datasets), and require further investigation

Titles: Obvious constraints



Depending on certain special document metadata



The titles may be duplicated (i.e., web datasets), and require further investigation



Time-consuming step of producing titles and requiring increasingly sophisticated domain knowledge

For a while, mainly evaluated on Wikipedia-based tasks (with well-written titles)!

Fact Verification

De Cao et al. 2021, Chen et al. 2022b,
Chen et al. 2022a, Thorne et al. 2022,
Lee et al. 2023

Entity Linking

De Cao et al. 2021, Chen et al. 2022b,
Lee et al. 2023

Slot Filling

De Cao et al. 2021, Chen et al. 2022b,
Lee et al. 2023

Open Domain QA

De Cao et al. 2021, Chen et al. 2022b,
Zhou et al. 2022, Lee et al. 2023

Dialogue

De Cao et al. 2021, Chen et al. 2022b,
Lee et al. 2023

Multi-hop retrieval

Lee et al. 2022

Word-based: URLs

- The URL of a document contains certain semantic information and can uniquely correspond to this document

- The URL of a document contains certain semantic information and can uniquely correspond to this document

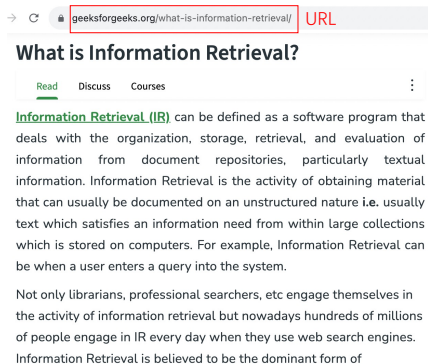

https://en.wikipedia.org/wiki/Nevada

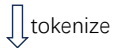

https :// en . Wikipedia . org / wiki / N e vada

- [Ren et al. \[2023\]](#) solely utilized tokenized URLs as the identifier

https://en.wikipedia.org/wiki/Nevada



https :// en . Wikipedia . org / wiki / N e vada

- [Ren et al. \[2023\]](#) solely utilized tokenized URLs as the identifier
- The tokenized symbols of URLs are well aligned with the vocabulary of the generative language model, thereby enhancing the generative capacity

- However, not all URLs provide sufficient semantic information

- However, not all URLs provide sufficient semantic information
- [Zhou et al. \[2022\]](#) proposed to combine the URL and the document title as docids to guarantee both the uniqueness and semantics of the identifiers

- However, not all URLs provide sufficient semantic information
- [Zhou et al. \[2022\]](#) proposed to combine the URL and the document title as docids to guarantee both the uniqueness and semantics of the identifiers

For a while, mainly evaluated on Web search datasets (with available URLs)!

MS MARCO

Nguyen et al. 2016

Natural Questions

Kwiatkowski et al. 2019

Trec-CAR

Dietz et al. 2017

Robust04

Voorhees et al. 2004

ClueWeb09-B

Clarke et al. 2010

Gov2

Clarke et al. 2004

URLs and subsequent work

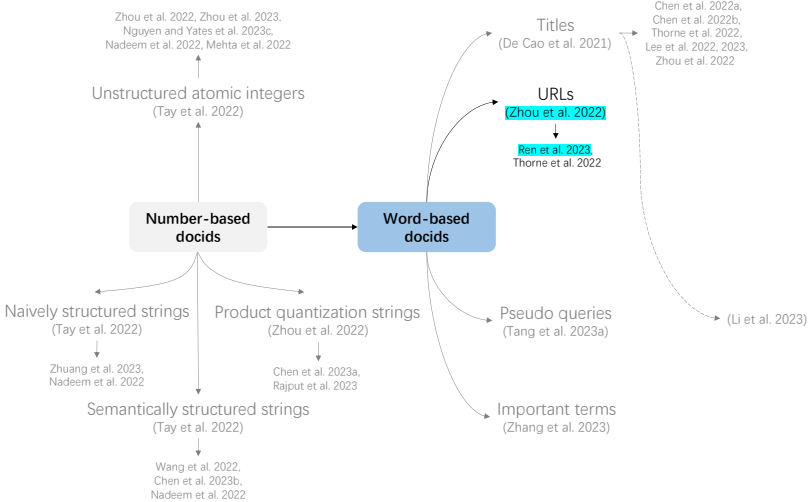

If the special document metadata is not available

It is necessary to design **automatic** docid generation techniques

- Doc2Query technique: pseudo queries are likely to be representative or related to the contents of documents

Word-based: Pseudo queries

- Doc2Query technique: pseudo queries are likely to be representative or related to the contents of documents

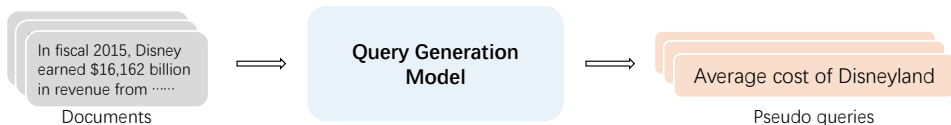

- Docid repetition problem
 - [Tang et al. \[2023a\]](#) uses the top 1 generated query as the docid for each document
 - Based on statistics, about 5% and 3% docids of documents are not unique in MS MARCO and Natural questions datasets, respectively
 - It is reasonable that different documents may share the same docid if they share very similar essential information

- Docid repetition problem
 - [Tang et al. \[2023a\]](#) uses the top 1 generated query as the docid for each document
 - Based on statistics, about 5% and 3% docids of documents are not unique in MS MARCO and Natural questions datasets, respectively
 - It is reasonable that different documents may share the same docid if they share very similar essential information
- Countermeasure
 - If a docid corresponds to multiple documents, **return all of them in a random order**, while keeping the relative order of documents corresponding to other docids

Pseudo queries and subsequent work

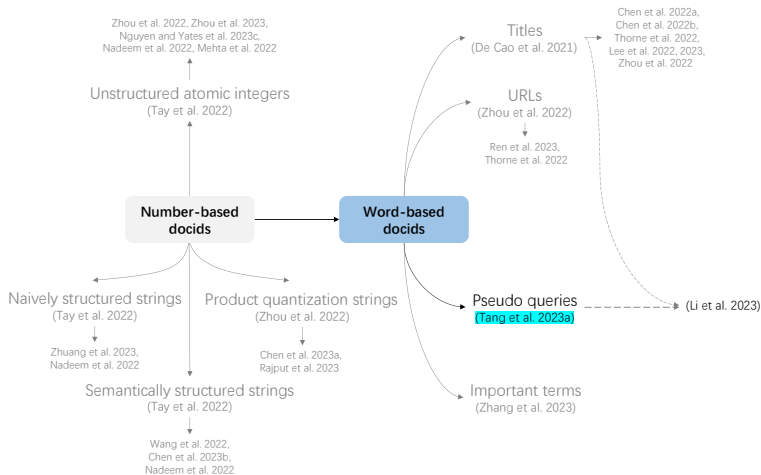

Pseudo queries and subsequent work

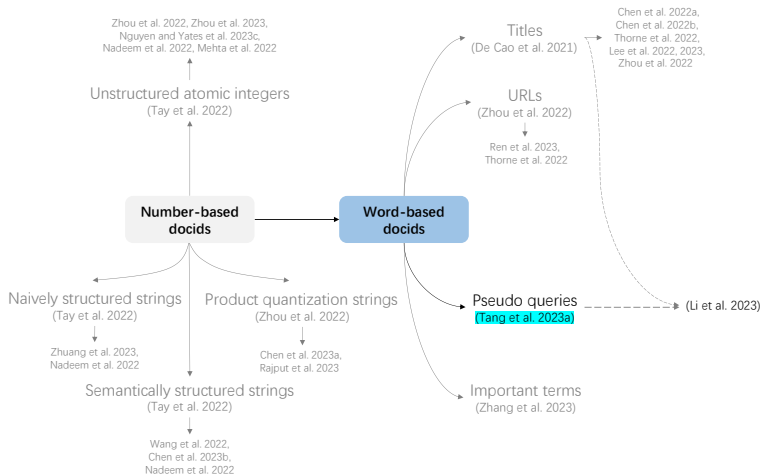

Without the requirements of certain document metadata, e.g., titles and URLs

Titles, URLs and pseudo queries:

Titles, URLs and pseudo queries:

- **One** pre-defined sequence

Titles, URLs and pseudo queries:

- **One** pre-defined sequence
- The requirement for the **exact generation**

Titles, URLs and pseudo queries:

- **One** pre-defined sequence
- The requirement for the **exact generation**
- The targeted document will be **missed** from the retrieval result if a false prediction about its identifier is made in **any step of the generation process**

The permutation of docids becomes critical

- **Any permutation** of the **term set** will be a **valid** identification for the corresponding document

- **Any permutation** of the **term set** will be a **valid** identification for the corresponding document
- **Important terms**: A set of document terms that have high **importance scores**

Important terms: AutoTSG [Zhang et al., 2023]

- Importance scores: The relevance scores of terms with respect to the query

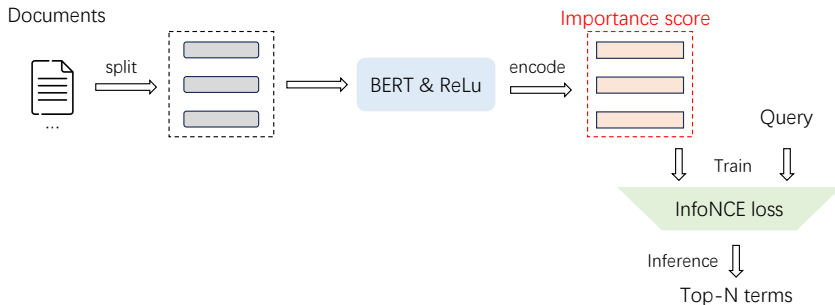

Docid repetition problem

- If the number of terms is sufficiently large, all documents within the corpus can be unique

Docid repetition problem

- If the number of terms is sufficiently large, all documents within the corpus can be unique
- For a moderate-scale corpus like Natural Questions, specifying 12 terms is already sufficient to ensure uniqueness

Important terms: AutoTSG [Zhang et al., 2023]

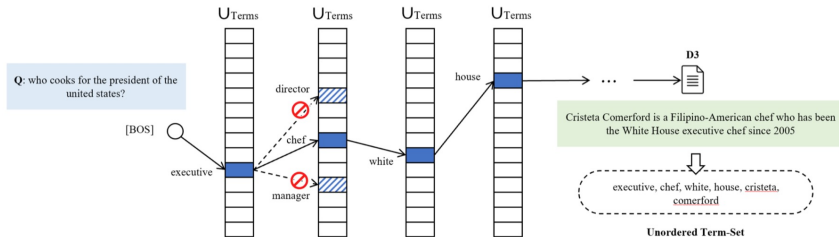

- Any permutation of the term-set identifier will lead to the retrieval of the corresponding document

Performance comparisons

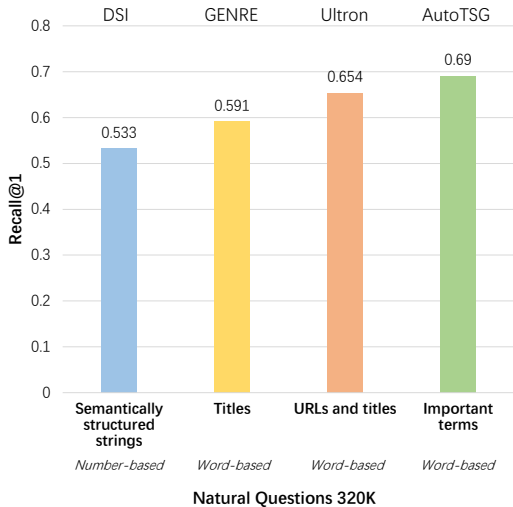

- Backbone: T5-base
- Using important term sets obtained through relevance matching as docids help represent the important information of the document
- This method also mitigates the issue of false pruning



Semantically related to the content of the document



Semantically related to the content of the document



Good interpretability

Word-based docids: Summary



Semantically related to the content of the document



Good interpretability



Rely on metadata or labeled data

Word-based docids: Summary



Semantically related to the content of the document



Good interpretability



Rely on metadata or labeled data



May lead to duplication

A single docid: Summary

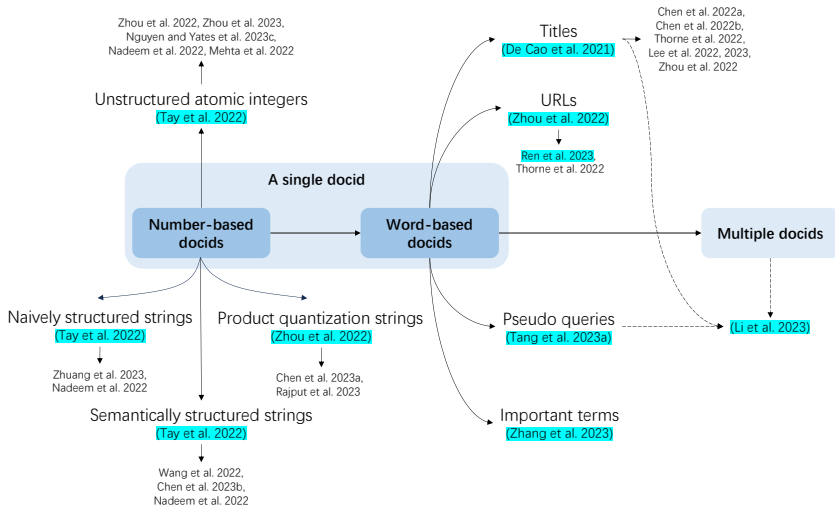



The design of a single docid is relatively straightforward

A single docid: Summary



The design of a single docid is relatively straightforward



The GR model may easily learn the one-to-one mapping relationship

A single docid: Summary



The design of a single docid is relatively straightforward



The GR model may easily learn the one-to-one mapping relationship



Single identifiers are typically short strings, providing limited information about the document

A single docid: Summary



The design of a single docid is relatively straightforward



The GR model may easily learn the one-to-one mapping relationship



Single identifiers are typically short strings, providing limited information about the document



A single type of identifier only represents a document from one view; and might be insufficient to effectively capture the entirety of the document's content

Multiple docids

- Multiple identifiers can provide complementary information from different views

- Multiple identifiers can provide complementary information from different views

Information retrieval 🌐 38 languages

From Wikipedia, the free encyclopedia

Information retrieval (IR) in [computing](#) and [information science](#) is the process of obtaining [information system](#) resources that are relevant to an information need from a collection of those resources. Searches can be based on [full-text](#) or other content-based indexing. Information retrieval is the [science](#)^[1] of searching for information in a document, searching for documents themselves, and also searching for the [metadata](#) that describes data, and for [databases](#) of texts, images or sounds.

History [edit]

The idea of using computers to search for relevant pieces of information was popularized in the article *As We May Think* by [Vannevar Bush](#) in 1945.^[1] It would appear that Bush was inspired by patents for a 'statistical machine' – filed by [Emanuel Goldberg](#) in the 1920s and '30s – that searched for documents stored on film.^[8] The first description of a computer searching for information was described by Holmstrom in 1948,^[9] detailing an early mention of the [Univac](#) computer. Automated information retrieval systems were introduced in the 1950s: one even featured in the 1957 romantic comedy, *Desk Set*. In the 1960s, the first large information retrieval research group was formed by [Gerard Salton](#) at Cornell. By the 1970s several different retrieval techniques had been shown to perform well on small [text corpora](#) such as the Cranfield collection (several thousand documents).^[17] Large-scale retrieval systems, such as the Lockheed Dialog system, came into use early in the 1970s.

Applications [edit]

Areas where information retrieval techniques are employed include (the entries are in alphabetical order within each category):

Overview of IR

History of IR

Applications of IR

Multi-view information

Multiple docids

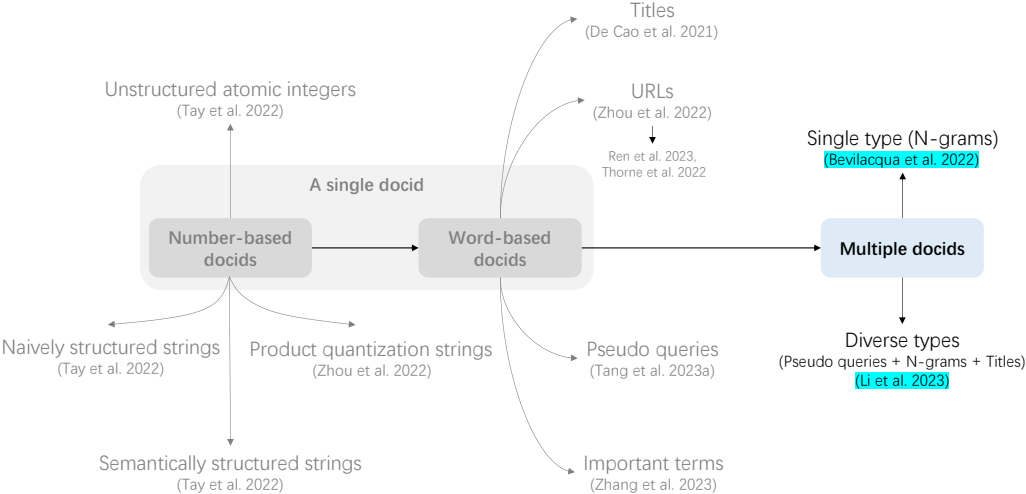

Multiple docids: Single type (N-grams) [[Bevilacqua et al., 2022](#)]

- All n-grams (i.e., substrings) in a document are treated as its possible identifiers

Multiple docids: Single type (N-grams) [Bevilacqua et al., 2022]

- All n-grams (i.e., substrings) in a document are treated as its possible identifiers
- Part of n-grams as identifiers during training: Only the terms from the document that have a **high overlap with the query** are chosen as the target docids

Carbon footprint

Carbon dioxide is released naturally by decomposition, ocean release and respiration. Humans contribute an increase of carbon dioxide emissions^{n-grams} by burning fossil fuels, deforestation, and cement production. Methane (CH₄) is largely released by coal, oil, and natural gas industries. Although methane is not mass-produced like carbon dioxide, it is still very prevalent.

Multiple docids: Single type (N-grams) [Bevilacqua et al., 2022]

Docid repetition problem

- A **heuristic scoring function** is designed to address this **during inference**

Docid repetition problem

- A **heuristic scoring function** is designed to address this **during inference**

We will discuss this in Section 5!

Multiple docids: Single type (Important n-grams) [Chen et al., 2023b]

- The **important n-grams** occurring in a document as its identifiers

Multiple docids: Single type (Important n-grams) [Chen et al., 2023b]

- The **important n-grams** occurring in a document as its identifiers
- N-gram importance
 - Step 1: The query and its relevant document are concatenated with special delimiter tokens as a single input sequence
 - Step 2: Feed it into the original BERT model to get the [CLS] vector
 - Step 3: The token importance is computed by averaging the [CLS]-token attention weights
 - Step 4: The importance for the n-gram is the average of these tokens' importance

Single type (Important n-grams) [Chen et al., 2023b]: An example

ID for document retrieval Important n-grams

1. was an American entrepreneur, industrial designer
2. Jobs was forced out of Apple
3. He died of respiratory arrest related

Steven Paul Jobs (February 24, 1955 – October 5, 2011) **was an American entrepreneur, industrial designer,** business magnate, media proprietor, and investor.

[...] In 1985, **Jobs was forced out of Apple** after a long power struggle with the company's board and its then-CEO John Sculley [...]

In 2003, Jobs was diagnosed with a pancreatic neuroendocrine tumor. **He died of respiratory arrest related** to the tumor on October 5, 2011 at the age of 56.

- Countermeasure for docid repetition problem: Similar to [Bevilacqua et al. \[2022\]](#)

Single type (N-grams) and subsequent work

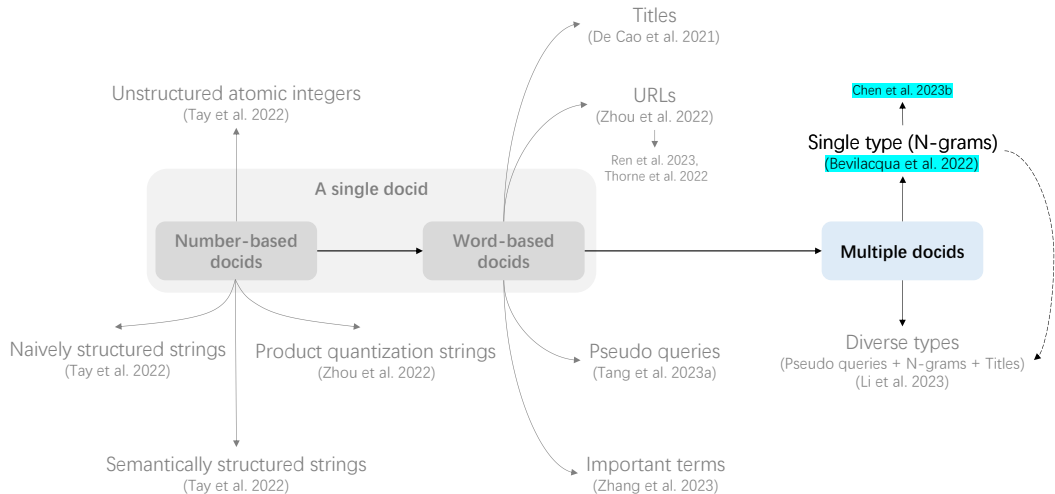

Multiple docids: Diverse types (MINDER) [Li et al., 2023]

Query: Who is the singer of *does he love you*?

↑ Relevant

Passage (https://en.wikipedia.org/wiki/Does_He_Love_You)

"Does He Love You" is a song written by Sandy Knox and Billy Stritch, and recorded as a duet by American country music artists Reba McEntire and Linda Davis. It was released in August 1993 as the first single from Reba's album "Greatest Hits Volume Two". It is one of country music's several songs about a love triangle. "Does He Love You" was written in 1982 by Billy Stritch.

Multiview Identifiers

Title: Does He Love You

Substrings: "Does He Love You" is a song ..., recorded as a duet by American country music artists Reba McEntire and Linda Davis, ...

Pseudo-queries:

Who wrote the song does he love you?

Who sings does he love you?

When was does he love you released by reba?

What is the first song in the album "Greatest Hits Volume Two" about?

- Three views of identifiers

Multiple docids: Diverse types (MINDER) [Li et al., 2023]

Query: Who is the singer of *does he love you*?

↑ Relevant

Passage (https://en.wikipedia.org/wiki/Does_He_Love_You)

"Does He Love You" is a song written by Sandy Knox and Billy Stritch, and recorded as a duet by American country music artists Reba McEntire and Linda Davis. It was released in August 1993 as the first single from Reba's album "Greatest Hits Volume Two". It is one of country music's several songs about a love triangle. "Does He Love You" was written in 1982 by Billy Stritch.

Multiview Identifiers

Title: Does He Love You

Substrings: "Does He Love You" is a song ..., recorded as a duet by American country music artists Reba McEntire and Linda Davis, ...

Pseudo-queries:

Who wrote the song does he love you?

Who sings does he love you?

When was does he love you released by reba?

What is the first song in the album "Greatest Hits Volume Two" about?

- Three views of identifiers
 - Title: Indicate the subject of a document

Multiple docids: Diverse types (MINDER) [Li et al., 2023]

Query: Who is the singer of *does he love you*?

↑ Relevant

Passage (https://en.wikipedia.org/wiki/Does_He_Love_You)

"Does He Love You" is a song written by Sandy Knox and Billy Stritch, and recorded as a duet by American country music artists Reba McEntire and Linda Davis. It was released in August 1993 as the first single from Reba's album "Greatest Hits Volume Two". It is one of country music's several songs about a love triangle. "Does He Love You" was written in 1982 by Billy Stritch.

Multiview Identifiers

Title: Does He Love You

Substrings: "Does He Love You" is a song ..., recorded as a duet by American country music artists Reba McEntire and Linda Davis, ...

Pseudo-queries:

Who wrote the song does he love you?

Who sings does he love you?

When was does he love you released by reba?

What is the first song in the album "Greatest Hits Volume Two" about?

- Three views of identifiers
 - Title: Indicate the subject of a document
 - Substrings (N-grams): Be also semantically related

Multiple docids: Diverse types (MINDER) [Li et al., 2023]

Query: Who is the singer of *does he love you*?

↑ Relevant

Passage (https://en.wikipedia.org/wiki/Does_He_Love_You)

"Does He Love You" is a song written by Sandy Knox and Billy Stritch, and recorded as a duet by American country music artists Reba McEntire and Linda Davis. It was released in August 1993 as the first single from Reba's album "Greatest Hits Volume Two". It is one of country music's several songs about a love triangle. "Does He Love You" was written in 1982 by Billy Stritch.

Multiview Identifiers

Title: Does He Love You

Substrings: "Does He Love You" is a song ..., recorded as a duet by American country music artists Reba McEntire and Linda Davis, ...

Pseudo-queries:

Who wrote the song does he love you?

Who sings does he love you?

When was does he love you released by reba?

What is the first song in the album "Greatest Hits Volume Two" about?

- Three views of identifiers
 - Title: Indicate the subject of a document
 - Substrings (N-grams): Be also semantically related
 - Pseudo-queries: Integrate multiple segments and contextualized information

Performance comparisons

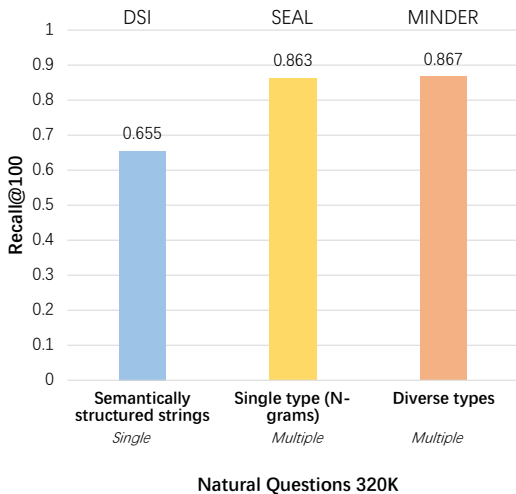

- Backbone: BART-large
- Results: Using multiple docids for a document yields better results than using a single docid



Multiple docids can provide a more **comprehensive** representation of the document, assisting the model in gaining a multifaceted understanding

Multiple docids: Summary



Multiple docids can provide a more **comprehensive** representation of the document, assisting the model in gaining a multifaceted understanding



Similar docids across different documents can reflect the **similarity** between the documents

Multiple docids: Summary



Multiple docids can provide a more **comprehensive** representation of the document, assisting the model in gaining a multifaceted understanding







Similar docids across different documents can reflect the **similarity** between the documents



GR models with the increased identifier numbers demand **more memory usage and inference time** compared to GR models with single identifiers

Multiple docids: Summary

-  Multiple docids can provide a more **comprehensive** representation of the document, assisting the model in gaining a multifaceted understanding
-  Similar docids across different documents can reflect the **similarity** between the documents
-  GR models with the increased identifier numbers demand **more memory usage and inference time** compared to GR models with single identifiers
-  It is challenging to design **discriminative** multiple identifiers for a document

Pre-defined static docids: Summary

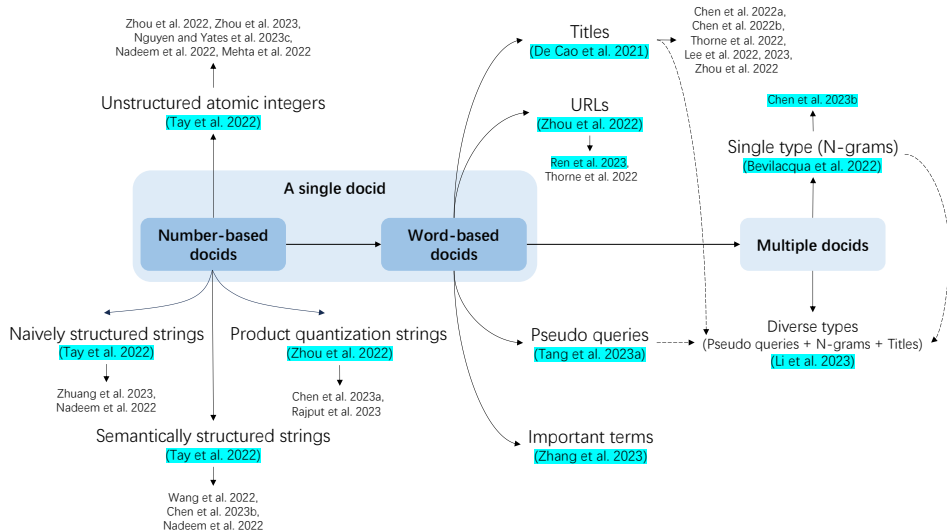

Pre-defined static docids: Summary

Docid type		Construction	Uniqueness	The degree of semantic connection to the document	Relying on labeled data	Relying on metadata
A single docid: Number-based	Unstructured atomic integers (Tay et al. 2022)	Easy	Yes	None	No	No
	Naively structured strings (Tay et al. 2022)	Easy	Yes	None	No	No
	Semantically structured strings (Tay et al. 2022)	Moderate	Yes	Weak	No	No
	Product quantization strings (Zhou et al. 2022)	Moderate	No	Moderate	No	No
A single docid: Word-based	Titles (De Cao et al. 2021)	Easy	No	Strong	No	Yes
	URLs (Zhou et al. 2022, Ren et al. 2023)	Easy	Yes	Strong	No	Yes
	Pseudo queries (Tang et al. 2023a)	Moderate	No	Strong	Yes	No
	Important terms (Zhang et al. 2023)	Hard	Yes	Strong	Yes	No
Multiple docids	Single type: N-grams (Bevilacqua et al. 2022)	Easy	No	Moderate	No	No
	Diverse types (Li et al. 2023)	Moderate	No	Strong	Yes	Yes

Pre-defined static docids: Obvious constrains

They are fixed and not learnable by training on the retrieval tasks

Pre-defined static docids: Obvious constrains

They are fixed and not learnable by training on the retrieval tasks



Not specifically optimized for retrieval tasks

Pre-defined static docids: Obvious constrains

They are fixed and not learnable by training on the retrieval tasks



Not specifically optimized for retrieval tasks



Difficult to learn semantics and relationships between documents

How to design learnable docids tailored for retrieval tasks?

- GenRet [Sun et al., 2023] learns to tokenize documents into short discrete representations via a discrete auto-encoding, jointly training with the retrieval task

- GenRet [Sun et al., 2023] learns to tokenize documents into short discrete representations via a discrete auto-encoding, jointly training with the retrieval task
- NOVO [Wang et al., 2023] uses unique n-gram sets identifying each document and can be generated in any order and can be optimized through retrieval tasks

Learnable docids: GenRet [Sun et al., 2023]

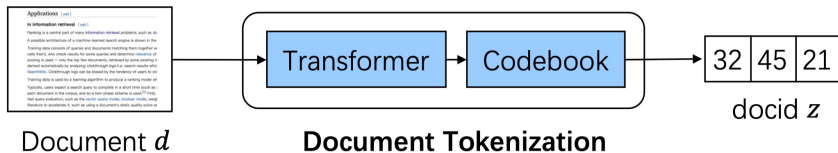

- Docid: A sequence of discrete numbers is the docid for a given document converted by a document tokenization model
- Training: Jointly training with a document tokenization task, reconstruction task and retrieval task

Learnable docids: GenRet [Sun et al., 2023]

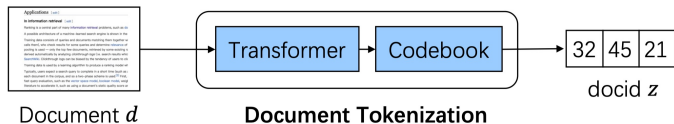

- Document tokenization task: Produce docids for documents

Learnable docids: GenRet [Sun et al., 2023]



- Reconstruction task: Learn to reconstruct a document based on a docid

Learnable docids: GenRet [Sun et al., 2023]

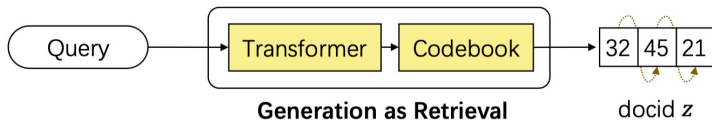

- Retrieval task: Generate relevant docids directly for a query

Docid repetition problem

- All corresponding documents are retrieved and shuffled in **an arbitrary order**



It can be optimized together with the ultimate goal of GR to better adapt to retrieval

Learnable docids: Summary



It can be optimized together with the ultimate goal of GR to better adapt to retrieval



A learnable approach can enable number-based docids like those in GenRet [[Sun et al., 2023](#)] to perform well

Learnable docids: Summary



It can be optimized together with the ultimate goal of GR to better adapt to retrieval



A learnable approach can enable number-based docids like those in GenRet [[Sun et al., 2023](#)] to perform well



It relies on complex task design for learning

Learnable docids: Summary



It can be optimized together with the ultimate goal of GR to better adapt to retrieval



A learnable approach can enable number-based docids like those in GenRet [[Sun et al., 2023](#)] to perform well



It relies on complex task design for learning





The learning process is complex, as docids change and require iterative learning

- **Shall we use randomize numbers as the docids?**
 - Random number strings can serve as docids, but their effectiveness is limited





- **Shall we use randomize numbers as the docids?**
 - Random number strings can serve as docids, but their effectiveness is limited
- **How to construct proper docids for the documents?**
 - Designing predefined or learnable docids based on the semantics of the documents

- **Shall we use randomize numbers as the docids?**
 - Random number strings can serve as docids, but their effectiveness is limited
- **How to construct proper docids for the documents?**
 - Designing predefined or learnable docids based on the semantics of the documents
- **Would the choices of different docids affect the model performance(effectiveness, capacity, etc.)?**
 - The length and quantity of docids both impact the effectiveness of the model's performance
 - The influence on capacity is yet to be explored





Docid design: Summary

Docid type				
Pre-defined	Single	Number-based	- Simplified construction	- Low interpretability - Moderate performance
		Word-based	- High interpretability - Good performance	- Single-perspective representation of documents
	Multiple	- Comprehensive document representations - Better performance	- Slightly more complex construction	
Learnable		- Adapting to GR objectives - Best performance	- Complex learning process	

Docid design: Summary

Docid type				
Pre-defined	Single	Number-based	- Simplified construction	- Low interpretability - Moderate performance
		Word-based	- High interpretability - Good performance	- Single-perspective representation of documents
	Multiple	 Comprehensive document representations - Better performance	- Slightly more complex construction	
Learnable		 Adapting to GR objectives - Best performance	- Complex learning process	

Docid design: Summary

Docid type				
Pre-defined	Single	Number-based	- Simplified construction	- Low interpretability - Moderate performance
		Word-based	- High interpretability - Good performance	- Single-perspective representation of documents
	Multiple	 Comprehensive document representations - Better performance	- Slightly more complex construction	
Learnable		 Adapting to GR objectives - Best performance	- Complex learning process	

Based on these docids

Model training → **Section 4!**

Model inference → **Section 5!**

Section 4:
Training approaches

Revisit the definition of generative retrieval

GR usually exploits a Seq2Seq encoder-decoder architecture to generate a ranked list of docids for an input query, in an autoregressive fashion

The common used training objective for both indexing and retrieval is **maximizing likelihood estimation** (MLE):

$$\begin{aligned}\mathcal{L}_{Global}(Q, D, I_D, I_Q; \theta) &= \mathcal{L}_{Indexing}(D, I_D; \theta) + \mathcal{L}_{Retrieval}(Q, I_Q; \theta) \\ &= - \sum_{d \in D} \log P(id | d; \theta) - \sum_{q \in Q} \sum_{id^q \in I_Q} \log P(id^q | q; \theta)\end{aligned}$$

Different learning scenarios based on the corpus

$$\begin{aligned}\mathcal{L}_{Global}(Q, \underline{D}, I_D, I_Q; \theta) &= \mathcal{L}_{Indexing}(\underline{D}, I_D; \theta) + \mathcal{L}_{Retrieval}(Q, I_Q; \theta) \\ &= - \sum_{d \in \underline{D}} \log P(id | d; \theta) - \sum_{q \in Q} \sum_{id^q \in I_Q} \log P(id^q | q; \theta)\end{aligned}$$

$$\begin{aligned}\mathcal{L}_{Global}(Q, \underline{D}, I_D, I_Q; \theta) &= \mathcal{L}_{Indexing}(\underline{D}, I_D; \theta) + \mathcal{L}_{Retrieval}(Q, I_Q; \theta) \\ &= - \sum_{d \in \underline{D}} \log P(id | d; \theta) - \sum_{q \in Q} \sum_{id^q \in I_Q} \log P(id^q | q; \theta)\end{aligned}$$

- **Stationary scenarios:** The document collection is fixed
- **Dynamic scenarios:** Information changes and new documents emerge incrementally over time

$$\begin{aligned}\mathcal{L}_{Global}(\underline{Q}, D, I_D, \underline{I_Q}; \theta) &= \mathcal{L}_{Indexing}(D, I_D; \theta) + \mathcal{L}_{Retrieval}(\underline{Q}, \underline{I_Q}; \theta) \\ &= - \sum_{d \in D} \log P(id | d; \theta) - \sum_{q \in Q} \sum_{id^q \in I_Q} \log P(\underline{id^q} | \underline{q}; \theta)\end{aligned}$$

According to the **availability of labeled data**, the training approaches in stationary scenarios can be generally classified into:

- **Supervised learning methods**
- **Pre-training methods**

- Learn the indexing task first, and then learn retrieval tasks
 - Step 1: $\mathcal{L}_{Indexing}(D, I_D; \theta) = - \sum_{d \in D} \log P(id | d; \theta)$
 - Step 2: $\mathcal{L}_{Retrieval}(Q, I_Q; \theta) = - \sum_{q \in Q} \sum_{id^q \in I_Q} \log P(id^q | q; \theta)$

- Learn the indexing task first, and then learn retrieval tasks
 - Step 1: $\mathcal{L}_{Indexing}(D, I_D; \theta) = - \sum_{d \in D} \log P(id | d; \theta)$
 - Step 2: $\mathcal{L}_{Retrieval}(Q, I_Q; \theta) = - \sum_{q \in Q} \sum_{id^q \in I_Q} \log P(id^q | q; \theta)$
- Learn indexing and retrieval tasks simultaneously in a **multitask** fashion

$$\begin{aligned}\mathcal{L}_{Global}(Q, D, I_D, I_Q; \theta) &= \mathcal{L}_{Indexing}(D, I_D; \theta) + \mathcal{L}_{Retrieval}(Q, I_Q; \theta) \\ &= - \sum_{d \in D} \log P(id | d; \theta) - \sum_{q \in Q} \sum_{id^q \in I_Q} \log P(id^q | q; \theta)\end{aligned}$$

Supervised learning: Basic training method

- Learn the indexing task first, and then learn retrieval tasks
 - Step 1: $\mathcal{L}_{Indexing}(D, I_D; \theta) = - \sum_{d \in D} \log P(id | d; \theta)$
 - Step 2: $\mathcal{L}_{Retrieval}(Q, I_Q; \theta) = - \sum_{q \in Q} \sum_{id^q \in I_Q} \log P(id^q | q; \theta)$
- Learn indexing and retrieval tasks simultaneously in a **multitask** fashion

$$\begin{aligned} \checkmark \mathcal{L}_{Global}(Q, D, I_D, I_Q; \theta) &= \mathcal{L}_{Indexing}(D, I_D; \theta) + \mathcal{L}_{Retrieval}(Q, I_Q; \theta) \\ &= - \sum_{d \in D} \log P(id | d; \theta) - \sum_{q \in Q} \sum_{id^q \in I_Q} \log P(id^q | q; \theta) \end{aligned}$$

- For a single docid representing a document
 - Indexing: Learn the relationships between document-docid pairs
 - Retrieval: Pair the query and the docid of each relevant document, and learn the relationships between query-docid pairs

Supervised learning: Multitask learning via MLE

- For a single docid representing a document
 - Indexing: Learn the relationships between document-docid pairs
 - Retrieval: Pair the query and the docid of each relevant document, and learn the relationships between query-docid pairs
- For multiple docids representing a document
 - Indexing: Pair the document and its each corresponding docid, and then learn the relationships between document-docid pairs
 - Retrieval: Pair the query and each docid of each relevant document, and learn the relationships between query-docid pairs

Limitation (1): Single document granularity

$$\begin{aligned}\mathcal{L}_{Global}(Q, D, I_D, I_Q; \theta) &= \mathcal{L}_{Indexing}(D, I_D; \theta) + \mathcal{L}_{Retrieval}(Q, I_Q; \theta) \\ &= - \sum_{d \in D} \log P(id | \underline{d}; \theta) - \sum_{q \in Q} \sum_{id^q \in I_Q} \log P(id^q | q; \theta)\end{aligned}$$

Limitation (1): Single document granularity

$$\begin{aligned}\mathcal{L}_{Global}(Q, D, I_D, I_Q; \theta) &= \mathcal{L}_{Indexing}(D, I_D; \theta) + \mathcal{L}_{Retrieval}(Q, I_Q; \theta) \\ &= - \sum_{d \in D} \log P(id | \underline{d}; \theta) - \sum_{q \in Q} \sum_{id^q \in I_Q} \log P(id^q | q; \theta)\end{aligned}$$

When indexing, memorizing each document at a single granularity, e.g., first L tokens or the full text, is **insufficient**, especially for long documents with rich semantics.

Supervised learning: Multi-granularity enhanced

- Given a document, the **important passages p** and **sentences s** are selected to augment the indexing data

Supervised learning: Multi-granularity enhanced

- Given a document, the **important passages** p and **sentences** s are selected to augment the indexing data

$$\mathcal{L}_{Indexing}(D, I_D; \theta) = -\left(\sum_{d \in D} \log P(id | d; \theta) + \sum_{p \in d} \log P(id | p; \theta) + \sum_{s \in d} \log P(id | s; \theta)\right)$$

Supervised learning: Multi-granularity enhanced

- Leading-style: Directly use the leading passages and sentences
- Summarization-style: Leverage the document summarization technique, e.g., TextRank, to highlight important parts

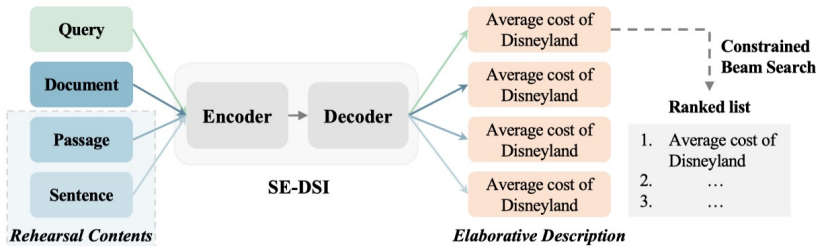

Comparisons

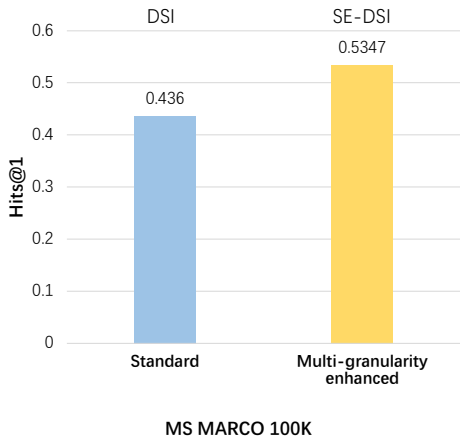

- Backbone: T5-base
- Multi-granularity representations of documents can comprehensively encode the documents, and further contribute to the retrieval

Limitation (2): The gap between indexing and retrieval

$$\begin{aligned}\mathcal{L}_{Global}(Q, D, I_D, I_Q; \theta) &= \mathcal{L}_{Indexing}(\underline{D}, I_D; \theta) + \mathcal{L}_{Retrieval}(\underline{Q}, I_Q; \theta) \\ &= - \sum_{d \in D} \log P(id | \underline{d}; \theta) - \sum_{q \in Q} \sum_{id^q \in I_Q} \log P(id^q | \underline{q}; \theta)\end{aligned}$$

Limitation (2): The gap between indexing and retrieval

$$\begin{aligned}\mathcal{L}_{Global}(Q, D, I_D, I_Q; \theta) &= \mathcal{L}_{Indexing}(\underline{D}, I_D; \theta) + \mathcal{L}_{Retrieval}(\underline{Q}, I_Q; \theta) \\ &= - \sum_{d \in D} \log P(id | \underline{d}; \theta) - \sum_{q \in Q} \sum_{id^q \in I_Q} \log P(id^q | \underline{q}; \theta)\end{aligned}$$

Long document in indexing V.S. Short query in retrieval

Limitation (2): The gap between indexing and retrieval

$$\begin{aligned}\mathcal{L}_{Global}(Q, D, I_D, I_Q; \theta) &= \mathcal{L}_{Indexing}(\underline{D}, I_D; \theta) + \mathcal{L}_{Retrieval}(\underline{Q}, I_Q; \theta) \\ &= - \sum_{d \in D} \log P(id | \underline{d}; \theta) - \sum_{q \in Q} \sum_{id^q \in I_Q} \log P(id^q | \underline{q}; \theta)\end{aligned}$$

Long document in indexing V.S. Short query in retrieval

The data distribution mismatch that occurs between the indexing and retrieval

Supervised learning: Pseudo query enhanced

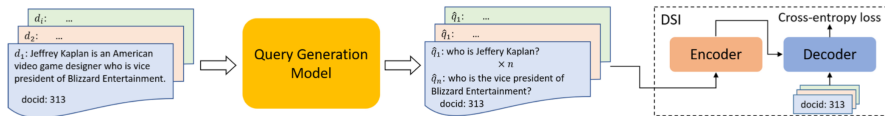

Using a set of **pseudo queries** pq generated from the document as the inputs of the indexing task

Supervised learning: Pseudo query enhanced

$$\mathcal{L}_{Indexing}(D, I_D; \theta) = - \sum_{d \in D} \log P(id | \underline{d}; \theta)$$



$$\mathcal{L}_{Indexing}(D, I_D; \theta) = - \sum_{pq \in D} \log P(id | \underline{pq}; \theta)$$

Supervised learning: Pseudo query enhanced

$$\mathcal{L}_{\text{Indexing}}(D, I_D; \theta) = - \sum_{d \in D} \log P(id \mid \underline{d}; \theta)$$



$$\mathcal{L}_{\text{Indexing}}(D, I_D; \theta) = - \sum_{pq \in D} \log P(id \mid \underline{pq}; \theta)$$

$$\mathcal{L}_{\text{Retrieval}}(Q, I_Q; \theta) = - \sum_{q \in Q} \sum_{id^q \in I_Q} \log P(id^q \mid q; \theta)$$

Comparisons

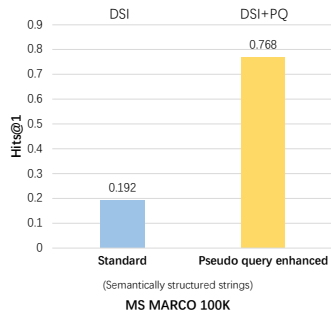
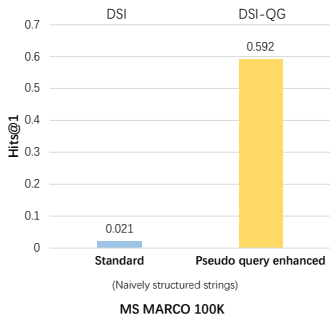

- Backbone: T5-base
- Using only pseudo synthetic queries to docid during indexing is an effective training strategy on MS MARCO [Pradeep et al., 2023]

Limitation (3): Limited labeled data

$$\mathcal{L}_{Global}(Q, D, I_D, I_Q; \theta) = \mathcal{L}_{Indexing}(D, I_D; \theta) + \mathcal{L}_{Retrieval}(Q, I_Q; \theta) \quad ?$$

What should we do if there is **no or few** labeled query-docid pairs?

Constructing **pseudo query-docid pairs** (PQ, I_Q^P) for the **pre-training** retrieval task

$$\mathcal{L}_{Pre-train}(PQ, D, I_D, I_Q^P; \theta) = \mathcal{L}_{Indexing}(D, I_D; \theta) + \underline{\mathcal{L}_{Retrieval}(PQ, I_Q^P; \theta)}$$

CorpusBrain [Chen et al., 2022b]: Pre-training

<p>INPUT: Apple Inc. is an American multinational [...] software and online services.</p>		<p>Apple Inc.</p> <p>Apple Inc. is an American <u>multinational technology company</u> that specializes in <u>consumer electronics, software and online services</u>. Apple is the <u>largest information technology company</u> by revenue [...]</p>	
<p>OUTPUT: Apple Inc.</p>	ISS	<p>Apple was founded as Apple Computer Company on April 1, 1976, by <u>Steve Jobs, Steve Wozniak and Ronald Wayne</u> to develop and sell Wozniak's <u>Apple I</u> personal computer [...] Apple <u>went public</u> in 1980, to instant financial success. The company developed computers featuring innovative <u>graphical user interfaces</u>, including the <u>original Macintosh</u>, announced in a critically acclaimed advertisement, "1984", directed by <u>Ridley Scott</u>. By 1985, the high cost of its products and power struggles between executives caused problems. Wozniak stepped back from Apple amicably, while Jobs resigned to found <u>NeXT</u>, taking some Apple employees with him.</p>	
<p>INPUT: Apple was founded as Apple Computer Company on April 1, 1976 [...] while Jobs resigned to found NeXT, taking some Apple employees with him.</p>		<p>[...] Apple became the first publicly traded U.S. company to be <u>valued at over \$1 trillion</u> in August 2018, then <u>\$2 trillion</u> in August 2020, and most recently <u>\$3 trillion</u> in January 2022. The company sometimes <u>receives criticism</u> regarding the labor practices of its contractors, its environmental practices, and its business ethics, including <u>anti-competitive practices</u> and materials sourcing. [...]</p>	
<p>OUTPUT: Apple Inc. [SEP] Tim Cook</p>	LPS		<p>INPUT: Apple became the first publicly traded U.S. company to be valued at over \$1 trillion in August 2018, then \$2 trillion in August 2020, and most recently \$3 trillion in January 2022. The company sometimes <u>receives criticism</u> regarding the labor practices of its contractors, its environmental practices, and its business ethics, including anti-competitive practices and materials sourcing.</p> <p>OUTPUT: Criticism of Apple Inc. HIP</p>

Based on Wikipedia, three pre-training retrieval tasks are constructed

CorpusBrain [Chen et al., 2022b]: Pre-training

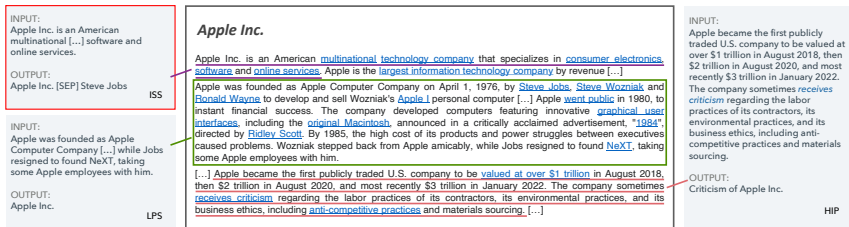

Inner Sentence Selection (ISS):

- Pseudo query (PQ): Randomly selected **inner sentence** from its document
- Docid (I_Q^P): Concatenated relevant **document titles**, i.e., “title [SEP] title [SEP] title”

CorpusBrain [Chen et al., 2022b]: Pre-training

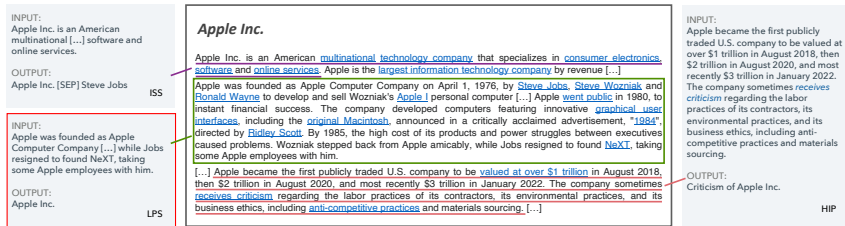

Lead Paragraph Selection (LPS):

- Pseudo query (PQ): A (lead) **paragraph** is sampled from the document
- Docid (I_Q^P): Concatenated relevant **document titles**

CorpusBrain [Chen et al., 2022b]: Pre-training

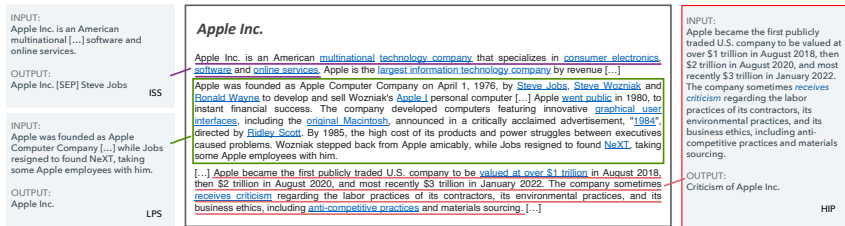

Hyperlink Identifier Prediction (HIP):

- Pseudo query (PQ): The **anchor context**, i.e., the surrounding contextual information in the anchor's corresponding sentence
- Docid (I_Q^P): The **document title** of the destination page

- **Pre-training:** Based on the three pre-training tasks, a large number of pseudo pairs of query and document identifiers are constructed. All the tasks are formulated by a standard seq2seq objective for the pre-training

- **Pre-training:** Based on the three pre-training tasks, a large number of pseudo pairs of query and document identifiers are constructed. All the tasks are formulated by a standard seq2seq objective for the pre-training
- **Fine-tuning:** CorpusBrain is fine-tuned using the processed data (in a Seq2Seq pair format) in downstream tasks

- **Pre-training:** Based on the three pre-training tasks, a large number of pseudo pairs of query and document identifiers are constructed. All the tasks are formulated by a standard seq2seq objective for the pre-training
- **Fine-tuning:** CorpusBrain is fine-tuned using the processed data (in a Seq2Seq pair format) in downstream tasks
- **Test:** Given a test query, the fine-tuned CorpusBrain utilizes constrained beam search to decode relevant docids

CorpusBrain [Chen et al., 2022b]: Performance

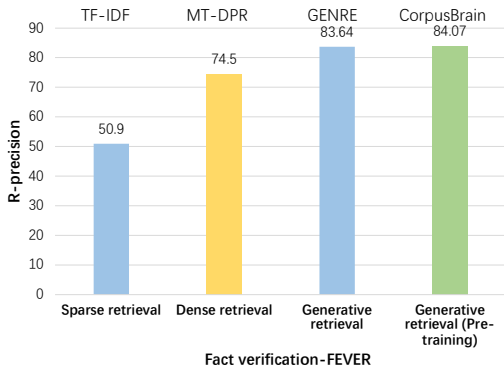

- In the KILT leaderboard, Corpusbrain achieved first place in 5 of them, second place in 1 task, and third place in 4 tasks, outperforming traditional pipelined approaches

Challenge (4): Pointwise optimization for GR

$$\begin{aligned}\mathcal{L}_{Global}(Q, D, I_D, I_Q; \theta) &= \mathcal{L}_{Indexing}(D, I_D; \theta) + \mathcal{L}_{Retrieval}(Q, I_Q; \theta) \\ &= - \sum_{d \in D} \log P(id | d; \theta) - \underbrace{\sum_{q \in Q} \sum_{id^q \in I_Q} \log P(id^q | q; \theta)}\end{aligned}$$

Challenge (4): Pointwise optimization for GR

$$\begin{aligned}\mathcal{L}_{Global}(Q, D, I_D, I_Q; \theta) &= \mathcal{L}_{Indexing}(D, I_D; \theta) + \mathcal{L}_{Retrieval}(Q, I_Q; \theta) \\ &= - \sum_{d \in D} \log P(id | d; \theta) - \underbrace{\sum_{q \in Q} \sum_{id^q \in I_Q} \log P(id^q | q; \theta)}\end{aligned}$$

- It assumes the likelihood for each relevant docid is **independent** of the other docids in the list for a query
- Ranking is a prediction task on **list of objects**

Challenge (4): Pointwise optimization for GR

$$\begin{aligned}\mathcal{L}_{Global}(Q, D, I_D, I_Q; \theta) &= \mathcal{L}_{Indexing}(D, I_D; \theta) + \mathcal{L}_{Retrieval}(Q, I_Q; \theta) \\ &= - \sum_{d \in D} \log P(id | d; \theta) - \underbrace{\sum_{q \in Q} \sum_{id^q \in I_Q} \log P(id^q | q; \theta)}\end{aligned}$$

- It assumes the likelihood for each relevant docid is **independent** of the other docids in the list for a query
- Ranking is a prediction task on **list of objects**

Listwise optimization for GR is necessary!

Training with position-aware ListMLE

- View the docid ranking problem as a **sequential learning process**, with each step targeting to maximize the corresponding stepwise probability distribution

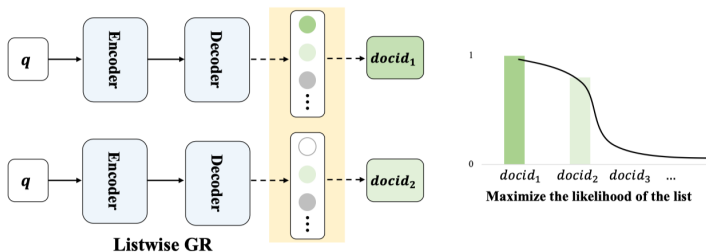

Given:

- A query q
- Its ground-truth docid list $\pi_q = [id^{(1)}, id^{(2)}, \dots]$, in descending order of relevance, where $id^{(1)}$ is the docid ranked at the first position, and $id^{(2)}$ is the docid ranked at the second position, and so on

Step 1: Maximize the following top-1 positional conditional probability:

$$P(id^{(1)} | q; \theta) = \frac{\exp(\tilde{P}(id^{(1)} | q; \theta))}{\sum_{j=1}^n \exp(\tilde{P}(id^{(j)} | q; \theta))},$$

where $\tilde{P}(id^{(i)} | q; \theta) = \frac{\log P(id^{(i)} | q; \theta)}{|id^{(i)}|}$, and $P(id^{(i)} | q; \theta)$ is the generated likelihood of the i -th relevant docid $id^{(i)}$ for q

Step 2: For $i = 2, \dots, n$, maximize the following i -th positional conditional probability given the preceding top $i - 1$ docids,

$$P(id^{(i)} \mid q, id^{(1)}, \dots, id^{(i-1)}; \theta) = \frac{\exp(\tilde{P}(id^{(i)} \mid q; \theta))}{\sum_{j=i}^n \exp(\tilde{P}(id^{(j)} \mid q; \theta))}$$

The learning process ends at step $n + 1$

Listwise loss with position importance

- Listwise probability with position importance

$$\begin{aligned} \min_{\theta} -\log P(\pi_q | q; \theta) \\ = -\alpha(1) \log P(id^{(1)} | q; \theta) - \sum_{i=2}^n \alpha(i) \log P(id^{(i)} | q, id^{(1)}, \dots, id^{(i-1)}; \theta), \end{aligned}$$

where the weight $\alpha(\cdot)$ is a decreasing function

- Listwise loss function incorporating the probability based on Plackett-Luce model

$$\mathcal{L}_{List}(q, \pi_q; \theta) = \sum_{i=1}^n \alpha(i) \left(-\tilde{P}(id^{(i)} | q; \theta) + \log \left(\sum_{k=i}^n \exp(\tilde{P}(id^{(k)} | q; \theta)) \right) \right)$$

$$\begin{aligned}\mathcal{L}_{Global}(Q, \underline{D}, I_D, I_Q; \theta) &= \mathcal{L}_{Indexing}(\underline{D}, I_D; \theta) + \mathcal{L}_{Retrieval}(Q, I_Q; \theta) \\ &= - \sum_{d \in \underline{D}} \log P(id | d; \theta) - \sum_{q \in Q} \sum_{id^q \in I_Q} \log P(id^q | q; \theta)\end{aligned}$$

Information changes and new documents emerge incrementally over time

Continual learning task: Formulation

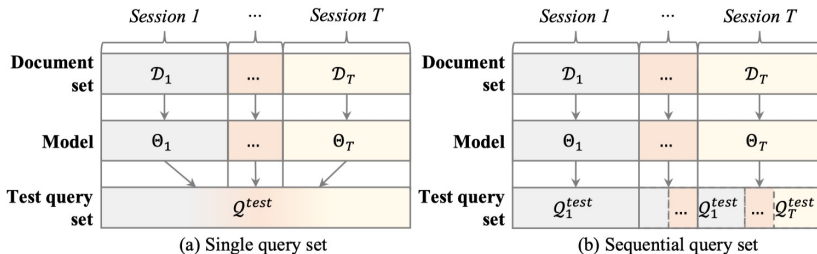

- **Initial model:** A large-scale base document set D_0 and sufficiently many labeled query-document pairs

Continual learning task: Formulation

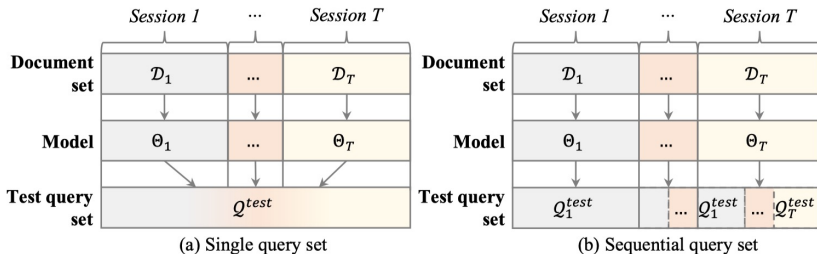

- **Initial model:** A large-scale base document set D_0 and sufficiently many labeled query-document pairs
- **New datasets:** T new datasets D_1, \dots, D_T , from T sessions arriving in a sequential manner, which are only composed of newly encountered documents without queries related to these documents

Continual learning task: Formulation

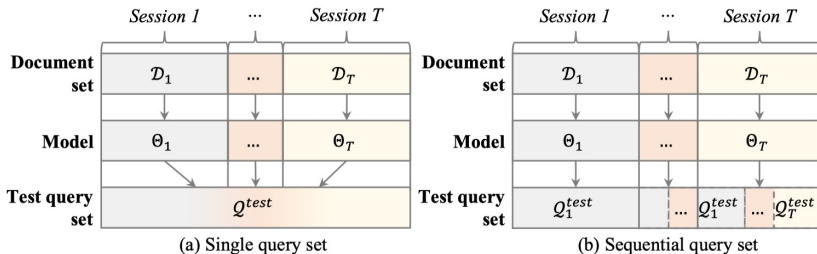

- **Initial model**: A large-scale base document set D_0 and sufficiently many labeled query-document pairs
- **New datasets**: T new datasets D_1, \dots, D_T , from T sessions arriving in a sequential manner, which are only composed of newly encountered documents without queries related to these documents
- **Model update**: The new dataset D_t and previous datasets D_0, \dots, D_{t-1}

Continual learning task: Evaluation

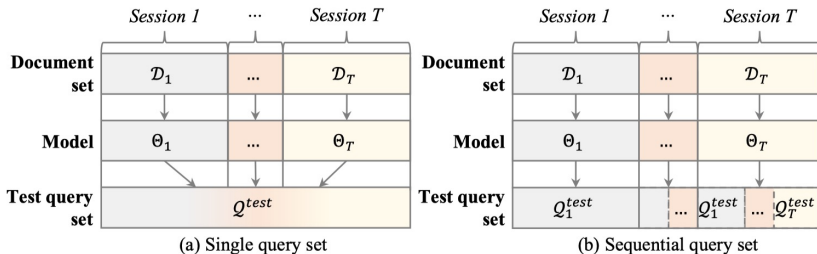

Two types of test query set for performance evaluation:

- **Single query set:** There is only one test query set, and their relevant documents arrive in different sessions
- **Sequential query set:** The test query set is specific for each session, and the relevant documents appear in existing sessions

Continual learning task: Evaluation

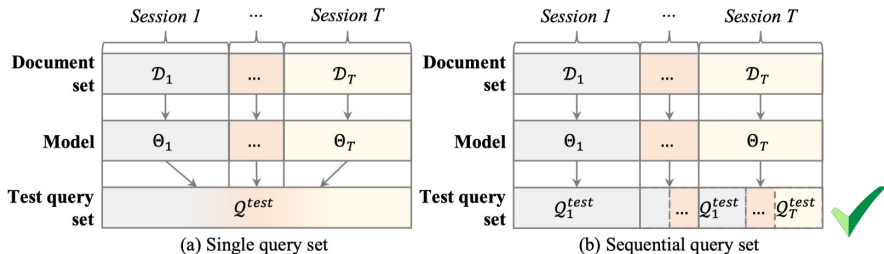

Two types of test query set for performance evaluation:

- **Single query set:** There is only one test query set, and their relevant documents arrive in different sessions
- **Sequential query set:** The test query set is specific for each session, and the relevant documents appear in existing sessions

Catastrophic forgetting

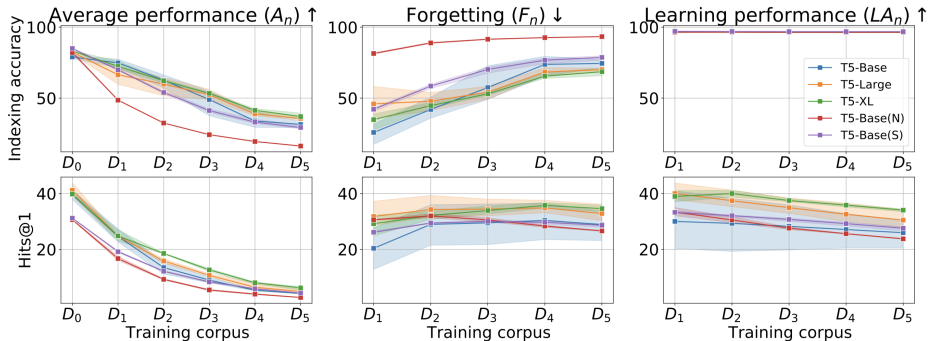

The GR model undergoes **severe forgetting** under continual indexing of new documents

Challenges of continual learning for GR

- How to incrementally index new documents with low computational and memory costs?

Challenges of continual learning for GR

- How to **incrementally index** new documents with **low computational and memory costs**?
- How to **prevent catastrophic forgetting** for previously indexed documents and **maintain the retrieval ability**?

CLEVER [Chen et al., 2023a]: Incrementally indexing new documents

Incremental product quantization (PQ) codes as identifiers: Update a partial quantization codebook according to two adaptive thresholds

Incremental product quantization (PQ) codes as identifiers: Update a partial quantization codebook according to two adaptive thresholds

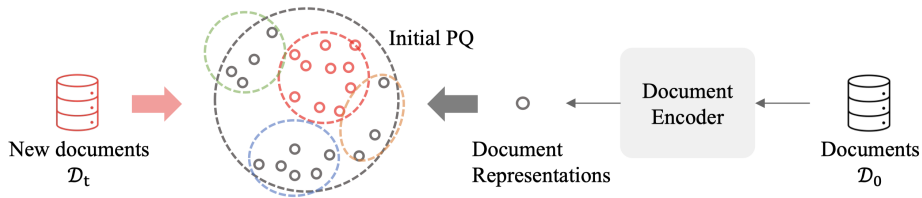

- **Build base PQ**
 - Centroids are obtained via clustering over document representations
 - Document representations are learned with a bootstrapped training process

CLEVER [Chen et al., 2023a]: Incremental product quantization

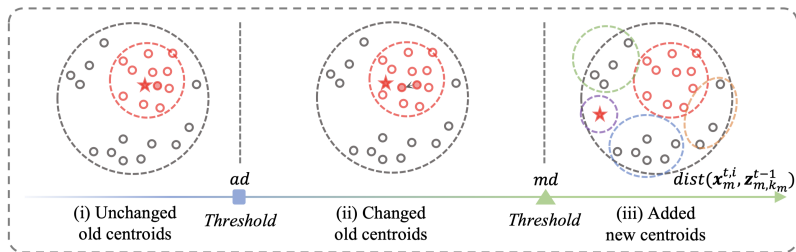

- Update adaptively
 - Dynamic thresholds: Average distance (ad); maximum distance (md)
 - Three types of update for centroid representation: Depend on contributions to centroid update

CLEVER [Chen et al., 2023a]: Preventing catastrophic forgetting

Memory-augmented learning mechanism: Form meaningful connections between old and new documents

CLEVER [Chen et al., 2023a]: Preventing catastrophic forgetting

Memory-augmented learning mechanism: Form meaningful connections between old and new documents

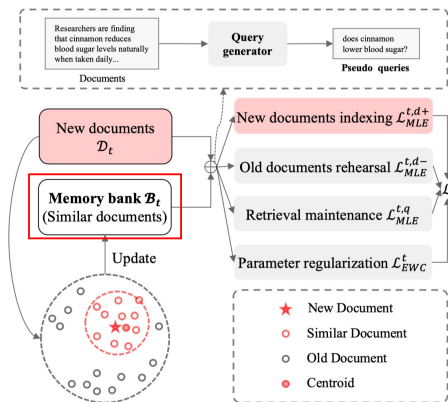

- **Dynamic memory bank:** Construct a memory bank with similar documents for each new session and replay the process of indexing them alongside the indexing of new documents

CLEVER [Chen et al., 2023a]: Memory-augmented learning mechanism

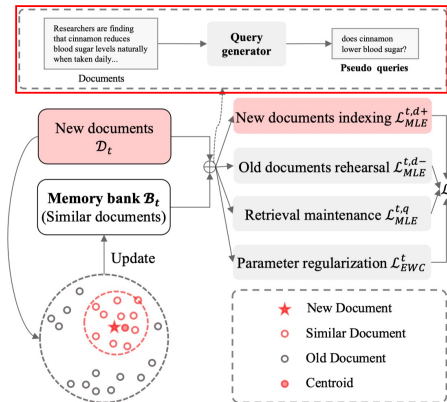

- **Pseudo query-docid pairs:** Train a query generator model to sample pseudo-queries for documents and supplement the query-docid pairs during indexing

CLEVER [Chen et al., 2023a]: Memory-augmented learning mechanism

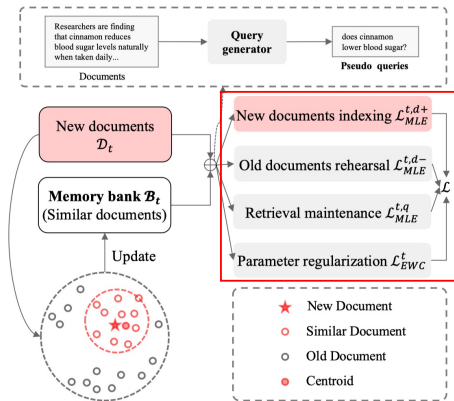

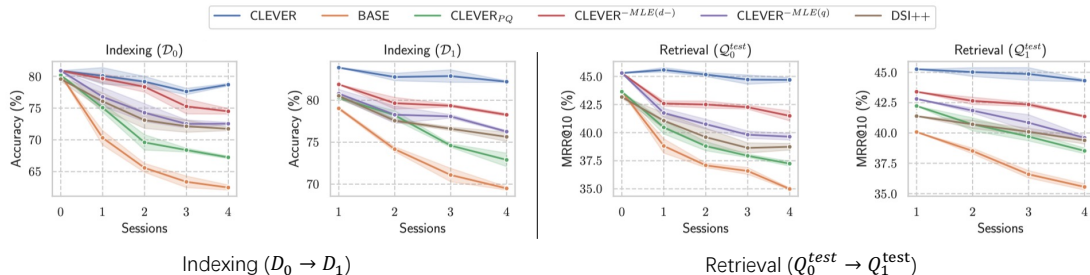

- **Sequentially training:** new documents indexing, old document rehearsal, retrieval maintenance losses and an elastic weight consolidation (EWC) loss as a regularization term

CLEVER [Chen et al., 2023a]: Performance



- CLEVER almost avoids catastrophic forgetting on both indexing and retrieval tasks, showing its effectiveness in a dynamic setting

A look back

Training approaches				
Standard approach (Tay et al. 2022)		- Simple	- Moderate performance	
Stationary	Multi-granularity enhanced (Tang et al. 2023a)	- Enhancing the memorization ability	- Requiring extra tools for selecting important paragraphs or sentences	
	Pseudo query enhanced (Zhuang et al. 2023)	- Reducing the gap between training and inference	- Depending on labeled data	
	Pre-training based (Chen et al. 2022b)	- Addressing the issue of no or limited labeled data	- Depending on the quality of pre-training corpora and task design	
Dynamic	DSI++ (Mehta et al. 2022)	Unstructured atomic integers	- Simple design	- High computational cost
		Experience replay	- Good performance	- Difficult to capture the relationship between old and new corpora
	CLEVER (Chen et al. 2023a)	Incremental product quantization	- High efficiency	- More complicated docid implementation
		Memory-augmented learning	- Better at capturing the relationship between old and new corpora - Better performance	- Extra memory bank

- **How to memorize the whole corpus effectively and efficiently?**

- **How to memorize the whole corpus effectively and efficiently?**
 - Multi-granularity enhanced document content
 - Pre-training
 - Listwise optimization

- **How to memorize the whole corpus effectively and efficiently?**
 - Multi-granularity enhanced document content
 - Pre-training
 - Listwise optimization
- **How to learn heterogeneous tasks well within a single model?**

- **How to memorize the whole corpus effectively and efficiently?**
 - Multi-granularity enhanced document content
 - Pre-training
 - Listwise optimization
- **How to learn heterogeneous tasks well within a single model?**
 - Pseudo query enhanced input

- **How to memorize the whole corpus effectively and efficiently?**
 - Multi-granularity enhanced document content
 - Pre-training
 - Listwise optimization
- **How to learn heterogeneous tasks well within a single model?**
 - Pseudo query enhanced input
- **How to handle a dynamically evolving document collection?**

- **How to memorize the whole corpus effectively and efficiently?**
 - Multi-granularity enhanced document content
 - Pre-training
 - Listwise optimization
- **How to learn heterogeneous tasks well within a single model?**
 - Pseudo query enhanced input
- **How to handle a dynamically evolving document collection?**
 - Low computational and memory costs
 - Maintaining the retrieval ability

- Binary relevance: Current relevance modeling mainly relies on MLE, struggling with **real-world annotation relevance**

- Binary relevance: Current relevance modeling mainly relies on MLE, struggling with **real-world annotation relevance**
- Pointwise optimization: MLE is essentially a pointwise approach, and it is considered sub-optimal due to its disregard for the fundamental principle that ranking involves making predictions about **lists**

- Binary relevance: Current relevance modeling mainly relies on MLE, struggling with **real-world annotation relevance**
- Pointwise optimization: MLE is essentially a pointwise approach, and it is considered sub-optimal due to its disregard for the fundamental principle that ranking involves making predictions about **lists**
- **Capacity**: The relationships between docids and training approaches have not been systematically explored

- Binary relevance: Current relevance modeling mainly relies on MLE, struggling with **real-world annotation relevance**
- Pointwise optimization: MLE is essentially a pointwise approach, and it is considered sub-optimal due to its disregard for the fundamental principle that ranking involves making predictions about **lists**
- **Capacity**: The relationships between docids and training approaches have not been systematically explored

Model inference → **Section 5!**

Section 5:
Inference strategies

- A **single identifier** to represent a document:
 - Constrained beam search with a prefix tree
 - Constrained greedy search with the inverted index

- A **single identifier** to represent a document:
 - Constrained beam search with a prefix tree
 - Constrained greedy search with the inverted index
- **Multiple identifiers** to represent a document
 - Constrained beam search with the FM-index
 - Scoring functions to aggregate the contributions of several identifiers

Single identifier: Constrained beam search with a prefix tree

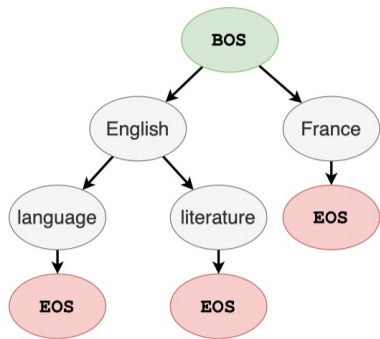

- For docids **considering order of tokens**
- **Applicable docids:** Naively structured strings, semantically structured strings, product quantization strings, titles, n-grams, URLs and pseudo queries

Single identifier: Constrained beam search with a prefix tree

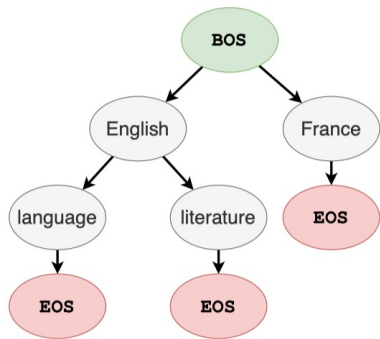

- For docids **considering order of tokens**
- **Applicable docids:** Naively structured strings, semantically structured strings, product quantization strings, titles, n-grams, URLs and pseudo queries
- Prefix tree: Nodes are annotated with tokens from the predefined candidate set. For each node, its children indicate all the allowed continuations from the prefix defined traversing the tree from the root to it

Example

Beam size = 2

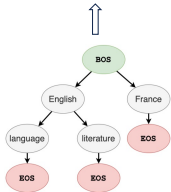
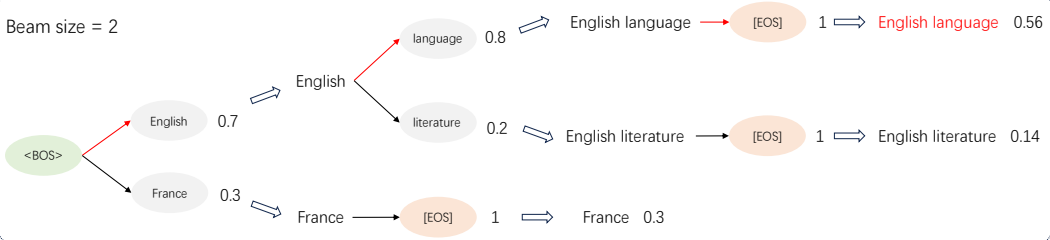

Single identifier: Constrained greedy search with the inverted index

- Applicable docids: Important terms

Single identifier: Constrained greedy search with the inverted index

- Applicable docids: Important terms
- **Inverted index table**: Enable the generation in **any permutations** (unordered docids) are constructed

Single identifier: Constrained greedy search with the inverted index

- Applicable docids: Important terms
- **Inverted index table**: Enable the generation in **any permutations** (unordered docids) are constructed
- Generation process: The model is expected to produce docids of the **highest generation likelihood**. At each step of generation, the terms from the inverted index table which give rise to the top-K generation likelihood are **greedily** selected

Constrained beam search vs. Constrained greedy search

Constrained beam search

Beam Size=2

Q: who cooks for the president of the united states?

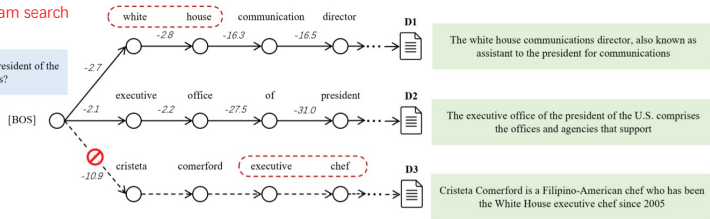

Constrained greedy search

Q: who cooks for the president of the united states?

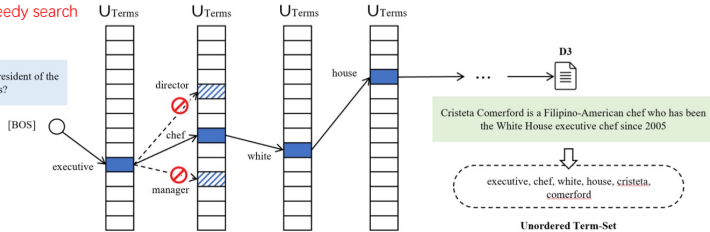

Multiple identifiers: Constrained beam search with the FM-index

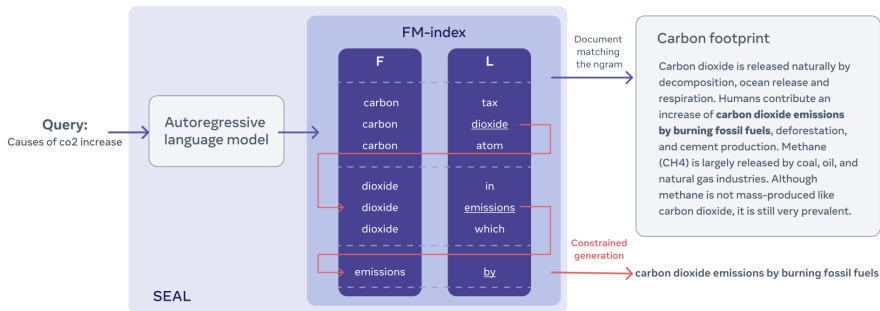

- Applicable docids: N-grams based docids

Multiple identifiers: Constrained beam search with the FM-index

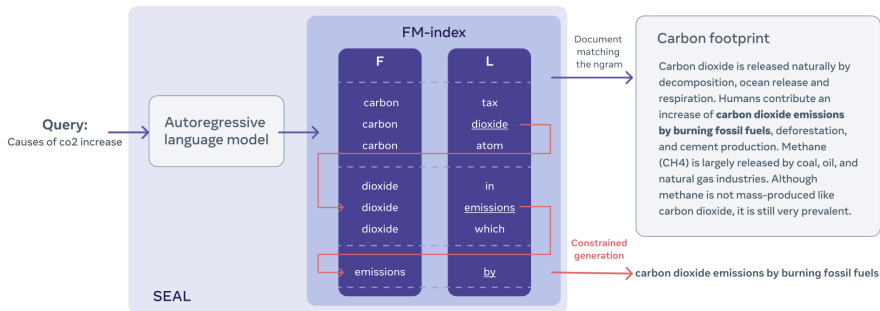

- Applicable docids: N-grams based docids
- FM-index: An index combining the Burrows-Wheeler Transform (BWT) with a few **small auxiliary data structures**

Given an input query q , we obtain the weight of each predicted n-gram n :

$$\text{score}(n, q) = \max\left(0, \log \frac{P(n|q)(1 - P(n))}{P(n)(1 - P(n|q))}\right),$$

where $P(n|q)$ is the probability of the generative model decoding n conditioned on q , and $p(n)$ denotes the unconditional n-gram probability.

How to **aggregate** the contribution of multiple generated n-gram identifiers to its corresponding documents?

The document-level rank score combines the n-gram level rank score $score(n, q)$ and **coverage weight** $cover(n, K)$:

$$score(d, q) = \sum_{n \in K^d} score(n, q)^\alpha \times cover(n, K),$$

where K denotes all the generated n-grams, K^d is the subset of n-grams in K that appear in d , α is a hyperparameter

For **docid repetition** problem

- Coverage weight $cover(n, K)$: Avoid the overscoring of very repetitive documents, where many similar n-grams are matched

$$cover(n, K) = 1 - \beta + \beta \frac{|set(n) \setminus C(n, K)|}{|set(n)|},$$

where β is a hyperparameter, $set(n)$ is the set of tokens in n , and $C(n, K)$ is the union of all tokens in K with top- g highest scores

The document-level rank score: **Sum of the scores of its covered docid**

$$\text{score}(q, d) = \sum_{i_d \in I_d} P(i_d|q),$$

where $P(i_d|q)$ is the generated likelihood score of the docid i_d of the document d . And I_d denotes the docids generated for d

Inference efficiency: Memory footprint

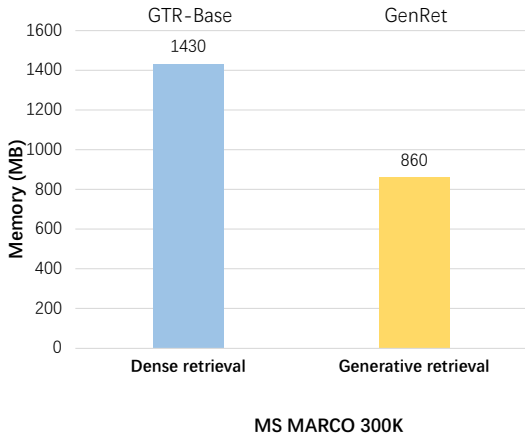

- The memory footprint of the GR model GenRet is **smaller** than that of the traditional dense retrieval method GTR, e.g., 1.6 times

Inference efficiency: Offline latency

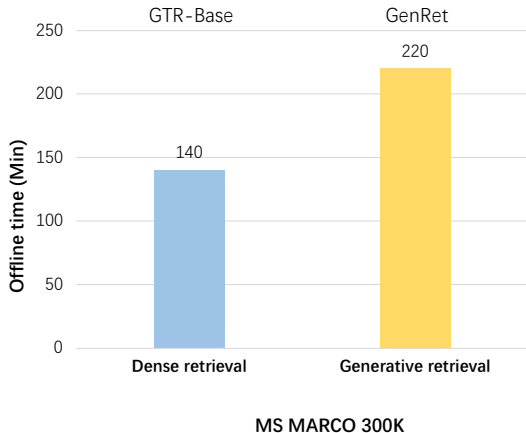

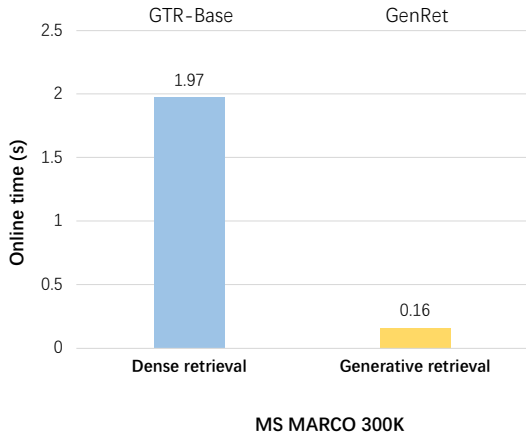

- GenRet takes a longer time for offline indexing, as the use of auxiliary models. GTR's offline time consumption comes from document encoding

Inference efficiency: Online latency



- Compared with the traditional dense retrieval model GTR, the GR model GenRet is **faster**, e.g., 12 times

A look back

Inference strategies			
A single docid	Constrained beam search with prefix tree (De Cao et al. 2021)	- Simple	- It cannot generate in an unordered manner
	Constrained greedy search with inverted index (Zhang et al. 2023)	- It can generate in any permutations of docids	- It may require handling a significant amount of duplicate terms
Multiple docids	Constrained beam search with FM-index (Bevilacqua et al. 2022)	<ul style="list-style-type: none">- It can store all the information of documents- The contributions of multiple docids comprehensively are considered	<ul style="list-style-type: none">- It cannot generate in an unordered manner- Complex construction- Complex aggregation functions
	Scoring functions (Li et al. 2023)	<ul style="list-style-type: none">- The contributions of multiple docids comprehensively are considered- Simple aggregation functions	<ul style="list-style-type: none">- Depending on design

- **How to generate valid docids?**

- **How to generate valid docids?**
 - Constrained generation mechanism based on prefix tree, inverted index table or FM-index

- **How to generate valid docids?**
 - Constrained generation mechanism based on prefix tree, inverted index table or FM-index
- **How to organize the docids for large scale corpus?**

- **How to generate valid docids?**
 - Constrained generation mechanism based on prefix tree, inverted index table or FM-index
- **How to organize the docids for large scale corpus?**
 - Exploiting the structured docid space

- **How to generate valid docids?**
 - Constrained generation mechanism based on prefix tree, inverted index table or FM-index
- **How to organize the docids for large scale corpus?**
 - Exploiting the structured docid space
- **How to generate a ranked list of docids for a query?**

- **How to generate valid docids?**
 - Constrained generation mechanism based on prefix tree, inverted index table or FM-index
- **How to organize the docids for large scale corpus?**
 - Exploiting the structured docid space
- **How to generate a ranked list of docids for a query?**
 - One-by-one generation based on likelihood probabilities

- **One-by-one generation:** There are limited works on one-time generation, i.e., directly decoding a sequence of docids

- **One-by-one generation:** There are limited works on one-time generation, i.e., directly decoding a sequence of docids
- **Dependency on prior knowledge:** Some heuristic scoring functions may require prior knowledge or manually designed rules

- **One-by-one generation:** There are limited works on one-time generation, i.e., directly decoding a sequence of docids
- **Dependency on prior knowledge:** Some heuristic scoring functions may require prior knowledge or manually designed rules
- **Not universally applicable:** Different tasks and scenarios may require different structures to handle decoding constraints

Limitations

- **One-by-one generation:** There are limited works on one-time generation, i.e., directly decoding a sequence of docids
- **Dependency on prior knowledge:** Some heuristic scoring functions may require prior knowledge or manually designed rules
- **Not universally applicable:** Different tasks and scenarios may require different structures to handle decoding constraints
- **Large-scale corpus:** Current docid space is limited to millions of documents

- **One-by-one generation**: There are limited works on one-time generation, i.e., directly decoding a sequence of docids
- **Dependency on prior knowledge**: Some heuristic scoring functions may require prior knowledge or manually designed rules
- **Not universally applicable**: Different tasks and scenarios may require different structures to handle decoding constraints
- **Large-scale corpus**: Current docid space is limited to millions of documents

Applications → **Section 6!**

Section 6: Applications

A range of target tasks

Fact Verification

De Cao et al. 2021, Chen et al. 2022b,
Chen et al. 2022a, Thorne et al. 2022,
Lee et al. 2023

Open Domain QA

De Cao et al. 2021, Chen et al. 2022b,
Zhou et al. 2022, Lee et al. 2023

Entity Linking

De Cao et al. 2021, Chen et al. 2022b,
Lee et al. 2023

Knowledge-intensive language tasks

A range of target tasks

Fact Verification

De Cao et al. 2021, Chen et al. 2022b,
Chen et al. 2022a, Thorne et al. 2022,
Lee et al. 2023

Open Domain QA

De Cao et al. 2021, Chen et al. 2022b,
Zhou et al. 2022, Lee et al. 2023

Entity Linking

De Cao et al. 2021, Chen et al. 2022b,
Lee et al. 2023

Multi-hop retrieval

Lee et al. 2022

Recommendation

Si et al. 2023, Rajput et al. 2023

Code retrieval

Naddem et al. 2022

More retrieval tasks

A range of target tasks

Fact Verification

De Cao et al. 2021, Chen et al. 2022b,
Chen et al. 2022a, Thorne et al. 2022,
Lee et al. 2023

Open Domain QA

De Cao et al. 2021, Chen et al. 2022b,
Zhou et al. 2022, Lee et al. 2023

Entity Linking

De Cao et al. 2021, Chen et al. 2022b,
Lee et al. 2023

Multi-hop retrieval

Lee et al. 2022

Recommendation

Si et al. 2023, Rajput et al. 2023

Code retrieval

Naddem et al. 2022

Official site retrieval

Tang et al. 2023a

Industry retrieval tasks

How to adapt a GR model for a task?

- Docid design
- Training approach
- Inference strategy

Knowledge-intensive language tasks

Slot Filling

INPUT:
Star Trek [SEP] creator

OUTPUT:
Gene Roddenberry

PROVENANCE:
17157886-1

zsRE

Open Domain QA

INPUT:
When did Star Trek go off the air

OUTPUT:
June 3, 1969

PROVENANCE:
17157886-5

NQ

INPUT:
Which Star Trek star directed Three Men and a Baby?

OUTPUT:
Leonard Nimoy

PROVENANCE:
17157886-4, 596639-7

TQA

INPUT:
Trekianta (formerly "TrekTrax Atlanta") is an annual convention for what American science fiction media franchise?

OUTPUT:
Star Trek

PROVENANCE:
17157886-1, 28789994-6

HoPo

 **KILT** Knowledge source:
5.9 Million Wikipedia pages

Star Trek ⁴ 17157886

Star Trek is an American media franchise based on the science fiction television series created by Gene Roddenberry.¹ [...] It followed the interstellar adventures of Captain James T. Kirk (William Shatner) and his crew aboard the starship USS "Enterprise", a space exploration vessel built by the United Federation of Planets in the 23rd century.² The "Star Trek" canon includes "The Original Series", an animated series, five spin-off television series, the film franchise, and further adaptations in several media.³

[...] The original 1966-69 series featured William Shatner as Captain James T. Kirk, Leonard Nimoy⁴ as Spock, DeForest Kelley as Dr. Leonard "Bones" McCoy, James Doohan as Montgomery "Scotty" Scott, Nichelle Nichols as Uhura, George Takei as Hikaru Sulu, and Walter Koenig as Pavel Chekov. During the series' first run, it earned several nominations for the Hugo Award for Best Dramatic Presentation, and won twice. [...] NBC canceled the show after three seasons; the last original episode aired on June 3, 1969.⁵ [...]

Three Men and a Baby ⁵⁹⁶⁶³⁹

Three Men and a Baby is a 1987 American comedy film directed by Leonard Nimoy⁷ and starring Tom Selleck, Steve Guttenberg, Ted Danson and Nancy Travis. [...]

Trekianta ²⁸⁷⁸⁹⁹⁹⁴

Trekianta is an annual "Star Trek" convention based in Atlanta, Georgia that places special emphasis on fan-based events, activities, programming and productions.⁶ [...]

Dialogue

INPUT:
I am a big fan of Star Trek, the American franchise created by Gene Roddenberry. I don't know much about it. When did the first episode air?
It debuted in 1996 and aired for 3 seasons on NBC.
What is the plot of the show?

OUTPUT:
William Shatner plays the role of Captain Kirk. He did a great job.

PROVENANCE:
17157886-2

WoW

Fact Checking

INPUT:
Star Trek had spin-off television series.

OUTPUT:
Supports

PROVENANCE:
17157886-3

FEV

Entity Linking

INPUT:
[...] Currently the site offers five movie collections ranging from \$149 for 10 [START_ENT] Star Trek [END_ENT] films to \$1,125 for the eclectic Movie Lovers' Collection of 75 movies. [...]

OUTPUT:
Star Trek

PROVENANCE:
17157886

CnWn

KILT example: GENRE [De Cao et al., 2021]

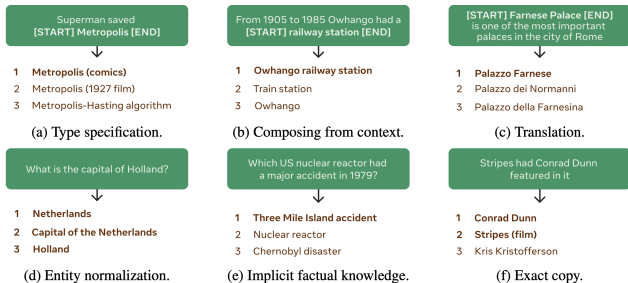

- Entity retrieval: Entity disambiguation, document retrieval, and etc
- Corpus: Wikipedia
- Input: Query
- Output: Destination/ relevant pages' title

- **Docid:** Titles
- **Training:** MLE objective with document-title and query-title pairs
- **Inference:** Constrained beam search with a prefix tree

KILT example: GENRE [De Cao et al., 2021]

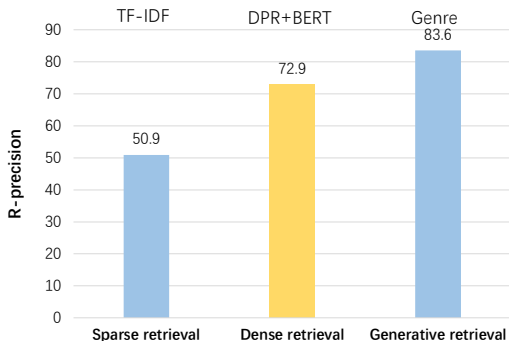

Fact verification-FEVER

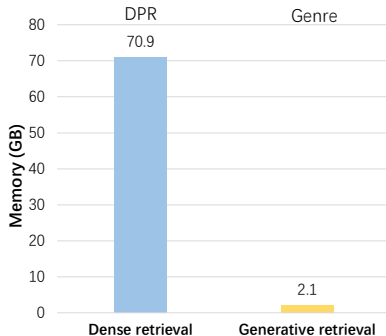

Wikipedia

- Fact verification: Verify a claim using multiple evidential sentences from trustworthy corpora
 - Input: Claim
 - Output: Support/Refute/Not enough information

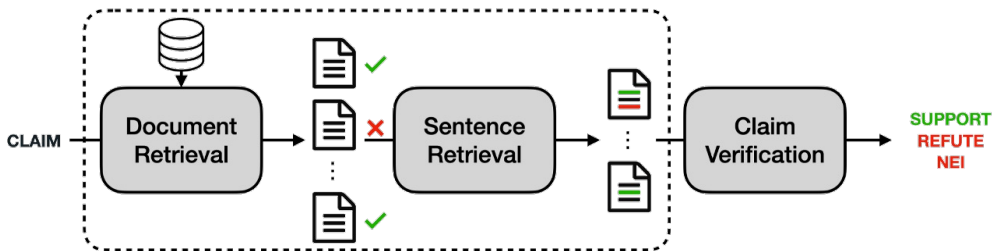

KILT example: GERE [Chen et al., 2022a]

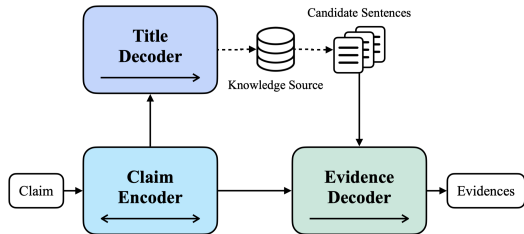

- **Docid:** Titles
- **Training:** MLE objective with claim-title and claim-evidence pairs
- **Inference:** Constrained beam search with a prefix tree

KILT example: GERE [Chen et al., 2022a]

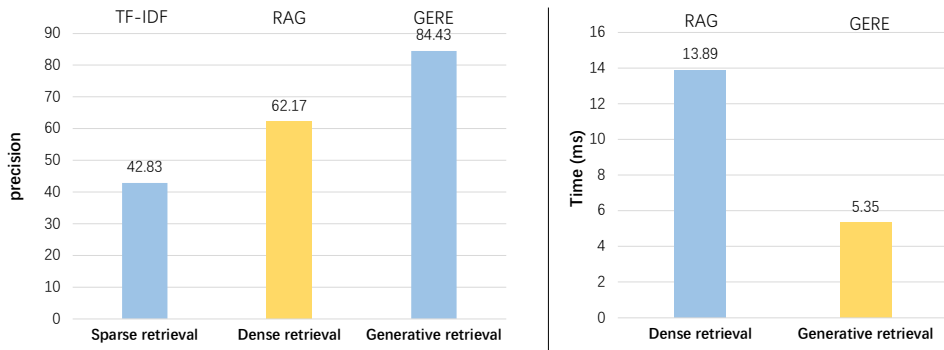

Fact verification-FEVER

Multi-hop retrieval [Lee et al., 2022]

Image source: Memory enhances ChatGPT performance in multi-hop QA

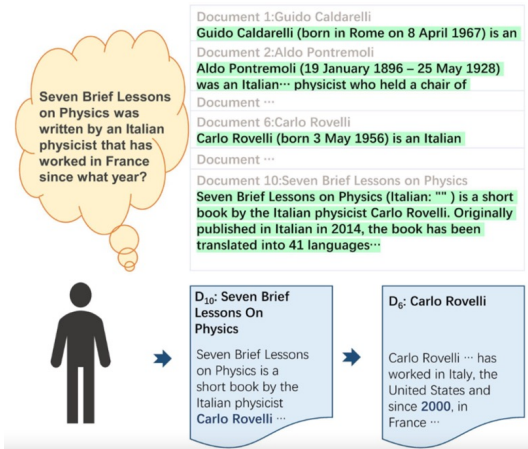

- Multi-hop retrieval
 - One needs to retrieve multiple documents that together provide sufficient evidence to answer the query
 - Previously retrieved items are appended to the query while iterating through multiple hops

"Generative multi-hop retrieval". Lee et al. [2022]

Multi-hop retrieval [Lee et al., 2022]

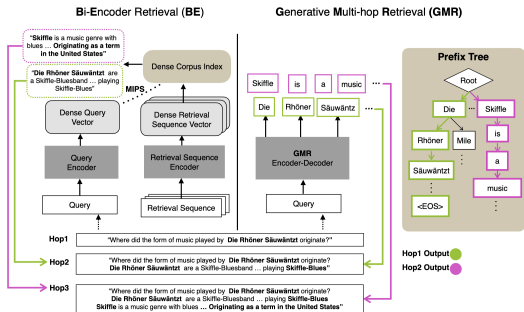

- **Docid:** Word-based answer
- **Jointly training:**
 - Indexing: Randomly select the first m words of the document as input and predict the remaining words with MLE
 - Retrieval: Learn pseudo query-answer pairs with MLE
- **Inference:** Constrained beam search with a prefix tree

Multi-hop retrieval [Lee et al., 2022]

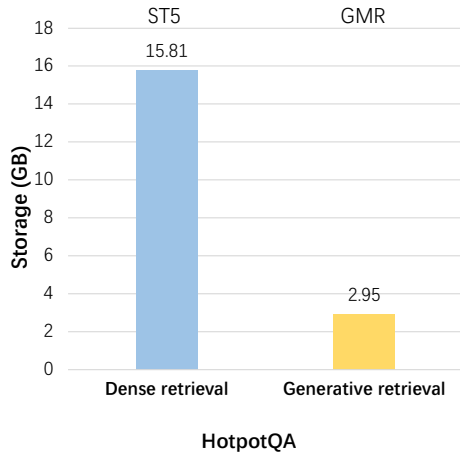
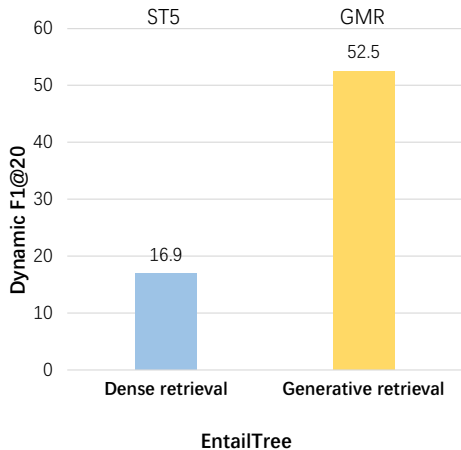

Recommendation [Rajput et al., 2023]

- Sequential recommendation: Help users discover content of interest and are ubiquitous in various recommendation domains
 - Input: User history
 - Output: Next item identifier

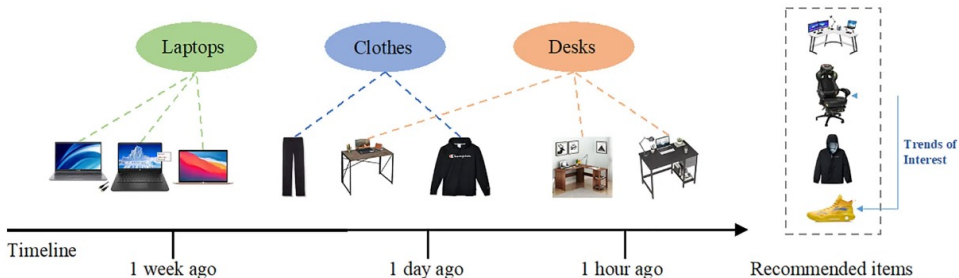

Recommendation [Rajput et al., 2023]

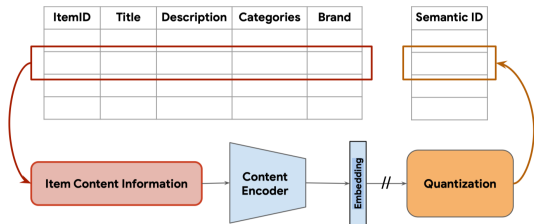

- **Docid**: Product quantization strings
- **Docid training**: Train a residual-quantized variational autoencoder model with a docid reconstruction loss and a multi-stage quantization loss

Recommendation [Rajput et al., 2023]

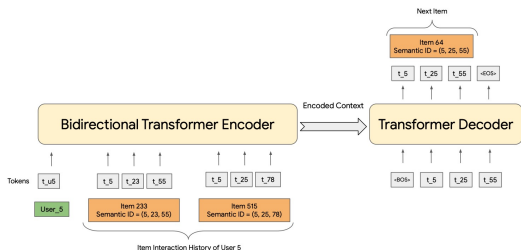

- **Recommendation training**

- Construct item sequences for every user by sorting chronologically the items they have interacted with
- Given item sequences, the recommender system's task is to predict the next item with MLE

- **Inference:** Beam search

Recommendation [Rajput et al., 2023]

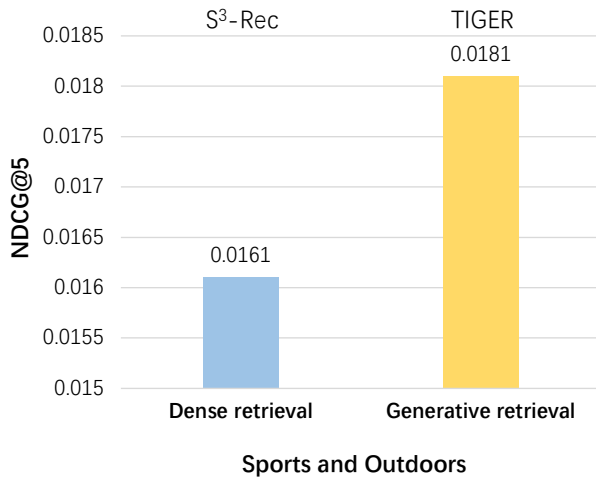

- Code retrieval: A model takes natural language queries as input and, in turn, relevant code samples from a database are returned
 - Input: Query
 - Output: Relevant code samples

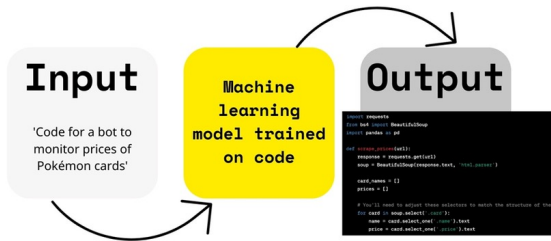

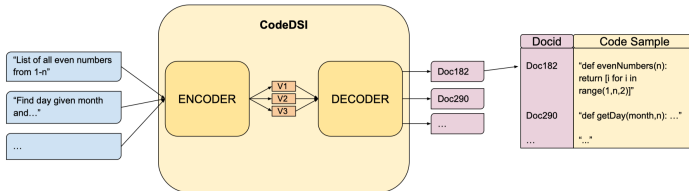

- **Docid**: Naively structured strings/ semantically structured strings
- **Training**: Standard indexing loss with code-docid pairs and retrieval loss with query-docid pairs
- **Inference**: Beam search

Code retrieval [Nadeem et al., 2022]

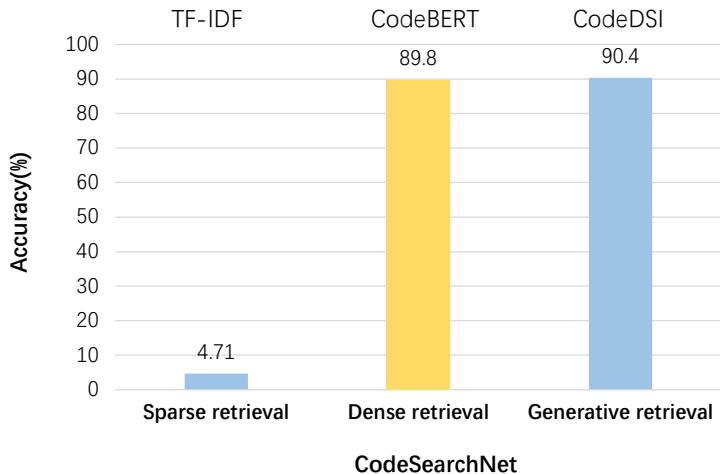

Official site retrieval [Tang et al., 2023a]

The image shows a Baidu search interface. The search bar contains the word "apple". Below the search bar, there are two main result sections. The first section, titled "Apple - 中国 [官方]", lists products like iPhone, Apple Watch, Mac, iPad, and AirPods, and includes the text "site URL: apple.com.cn". The second section, titled "Apple (中国大陆) - 官方网站 [官方]", features a black square with the Apple logo and text about the Apple Watch Series 9. Below these is a section for "apple - 百度翻译", which shows the Chinese character "苹果" with its English pronunciation and a translation example: "Have an apple to keep you going till dinner time." The bottom of the screenshot shows the footer "fanyi.baidu.com".

- Official sites: Web pages that have been operated by universities, departments, or other administrative units

Official site retrieval [Tang et al., 2023a]

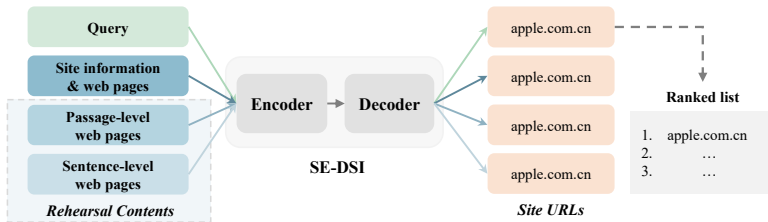

- **Docid:** Unique site URLs
- **Jointly training:**
 - Indexing: Learn site information (site name/ site domain/ ICP record) - docid pairs, web pages-docid pairs, and important web pages-docid pairs with MLE
 - Retrieval: Learn query - docid pairs with MLE
- **Inference:** Constrained beam search with a prefix tree

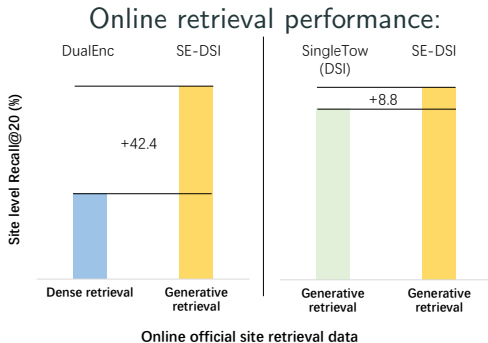

Inference comparison:

- Memory footprint: SE-DSI's memory is reduced by about 31 times compared to RepBERT
- Inference speed: SE-DSI's speed is significantly improved by about 2.5 times compared to RepBERT

- Generalizing to **ultra-large-scale corpora** remains a challenge
- How to adapt to the significant **dynamic** changes in large-scale corpora for **online** applications

Section 7: Challenges & Opportunities

- **Definition & preliminaries**
- **Generative retrieval: docid design**
 - Single docids: number-based and word-based identifiers
 - Multiple docids: single type and diverse types
- **Generative retrieval: training approaches**
 - Stationary scenarios: supervised learning and pre-training
 - Dynamic scenarios
- **Generative retrieval: inference strategies**
 - Single docids: constrained greedy search, constrained beam search and FM-index
 - Multiple docids: aggregation functions
- **Generative retrieval: applications**

Information retrieval in the era of language models

Information retrieval in the era of language models

- Encode the **global information** in corpus; optimize in an **end-to-end way**
- The semantic-level **association** extending beyond mere signal-level matching

Information retrieval in the era of language models

- Encode the **global information** in corpus; optimize in an **end-to-end way**
- The semantic-level **association** extending beyond mere signal-level matching
- Constraint decoding over **thousand-level vocabulary**
- Internal index which **eliminates** large-scale external index

Cons of generative retrieval: Scalability

- Highly dynamic corpora
 - Document addition, removal and updates
 - How to keep such GR models up-to-date?
 - How to learn on new data without forgetting old ones?

Cons of generative retrieval: Scalability

- **Highly dynamic corpora**
 - Document addition, removal and updates
 - How to keep such GR models up-to-date?
 - How to learn on new data without forgetting old ones?
- **Multi-modal/granularity/language search tasks**
 - Different search tasks leverage very different indexes
 - How to unify different search tasks into a single generative form?
 - How to capture task specifications while obtaining the shared knowledge?

Cons of generative retrieval: Controllability

For an issue, it is often unclear what modeling knobs one should turn to fix the model's behavior

Cons of generative retrieval: Controllability

For an issue, it is often unclear what modeling knobs one should turn to fix the model's behavior

- **Interpretability**
 - Black-box neural models
 - How to provide credible explanation for the retrieval process and results?

Cons of generative retrieval: Controllability

For an issue, it is often unclear what modeling knobs one should turn to fix the model's behavior

- **Interpretability**
 - Black-box neural models
 - How to provide credible explanation for the retrieval process and results?
- **Debuggable**
 - Attribution analysis: how to conduct causal traceability analysis on the causes, key links and other factors of specific search results?
 - Model editing: how to accurately and conveniently modify training data or tune hyperparameters in the loss function?

Cons of generative retrieval: Controllability

For an issue, it is often unclear what modeling knobs one should turn to fix the model's behavior

- **Interpretability**
 - Black-box neural models
 - How to provide credible explanation for the retrieval process and results?
- **Debuggable**
 - Attribution analysis: how to conduct causal traceability analysis on the causes, key links and other factors of specific search results?
 - Model editing: how to accurately and conveniently modify training data or tune hyperparameters in the loss function?
- **Robustness**
 - When a new technique enters into the real-world application, it is critical to know not only how it works in average, but also how would it behave in abnormal situations

Cons of generative retrieval: User-centered

Searching is a **socially** and **contextually** situated activity with diverse set of goals and needs for support that must not be boiled down to a combination of text matching and text generating algorithms [[Shah and Bender, 2022](#)]

Cons of generative retrieval: User-centered

Searching is a **socially** and **contextually** situated activity with diverse set of goals and needs for support that must not be boiled down to a combination of text matching and text generating algorithms [[Shah and Bender, 2022](#)]

- Human information seeking behavior
- Transparency
- Provenance
- Accountability

Cons of generative retrieval: Performance

The current performance of GR can only be compared to the **index-retrieval** stage of traditional methods, and it has **not yet** achieved the additional improvement provided by **re-ranking**

- **Closed-book**: The language model is the only source of knowledge leveraged during generation, e.g.,
 - Capturing document ids in the language models
 - Language models as retrieval agents via prompting
- **Open-book**: The language model can draw on external memory prior to, during and after generation, e.g.,
 - Retrieve-augmented generation of answers
 - Tool-augmented generation of answers

So much to do ...

Cater for long-term effects

- How to combine the short-term **relevance** goal with long-term goals such as diversity

So much to do . . .

Cater for **long-term effects**

- How to combine the short-term **relevance** goal with long-term goals such as diversity

Address needs of **interactive environments**

- Interactive systems must operate under high degrees of uncertainty
 - User feedback, non-stationarity, exogenous factor, user preferences, . . .

So much to do . . .

Cater for **long-term effects**

- How to combine the short-term **relevance** goal with long-term goals such as diversity

Address needs of **interactive environments**

- Interactive systems must operate under high degrees of uncertainty
 - User feedback, non-stationarity, exogenous factor, user preferences, . . .

Searching/recommending **slates of items**

- Interface of many search/recommendation platforms requires showing combinations of results to users on the same page
- Different combinations may lead to different short vs. long-term outcomes
- Problem thus becomes combinatorial in nature, intractable for most applications

So much to do ...

Information retrieval meets large language models (LLMs)!

Q & A

Thank you for joining us today!

All materials are available at

<https://sigir-ap2023-generative-ir.github.io/>

Contact information

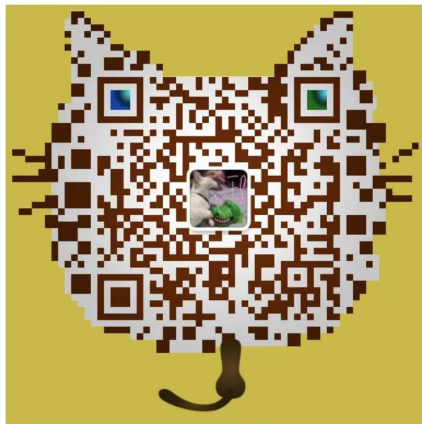

tangyubao21b@ict.ac.cn

References

References i

- M. Bevilacqua, G. Ottaviano, P. Lewis, W.-t. Yih, S. Riedel, and F. Petroni. Autoregressive search engines: Generating substrings as document identifiers. In *Advances in Neural Information Processing Systems*, pages 31668–31683, 2022.
- J. Chen, R. Zhang, J. Guo, Y. Fan, and X. Cheng. Gere: Generative evidence retrieval for fact verification. In *Proceedings of the 45th International ACM SIGIR Conference on Research and Development in Information Retrieval*, pages 2184–2189, 2022a.
- J. Chen, R. Zhang, J. Guo, Y. Liu, Y. Fan, and X. Cheng. Corpusbrain: Pre-train a generative retrieval model for knowledge-intensive language tasks. In *Proceedings of the 31st ACM International Conference on Information & Knowledge Management*, pages 191–200, 2022b.
- J. Chen, R. Zhang, J. Guo, M. de Rijke, W. Chen, Y. Fan, and X. Cheng. Continual learning for generative retrieval over dynamic corpora. In *Proceedings of the 32nd ACM Conference on Information and Knowledge Management*, 2023a.
- J. Chen, R. Zhang, J. Guo, M. de Rijke, Y. Liu, Y. Fan, and X. Cheng. A unified generative retriever for knowledge-intensive language tasks via prompt learning. In *46th International ACM SIGIR Conference on Research and Development in Information Retrieval*, pages 1448–1457, 2023b.

References ii

- N. De Cao, G. Izacard, S. Riedel, and F. Petroni. Autoregressive entity retrieval. In *International Conference on Learning Representations*, 2021.
- R. Deffayet, T. Thonet, D. Hwang, V. Lehoux, J.-M. Renders, and M. de Rijke. Sardine: A simulator for automated recommendation in dynamic and interactive environments. *ACM Transactions on Recommender Systems*, Submitted.
- L. Heck and S. Heck. Zero-shot visual slot filling as question answering. *arXiv preprint arXiv:2011.12340*, 2020.
- J. D. M.-W. C. Kenton and L. K. Toutanova. Bert: Pre-training of deep bidirectional transformers for language understanding. In *Proceedings of NAACL-HLT*, pages 4171–4186, 2019.
- H. Lee, S. Yang, H. Oh, and M. Seo. Generative multi-hop retrieval. In *Proceedings of the 2022 Conference on Empirical Methods in Natural Language Processing*, pages 1417–1436, 2022.
- Y. Li, N. Yang, L. Wang, F. Wei, and W. Li. Multiview identifiers enhanced generative retrieval. In *61st Annual Meeting of the Association for Computational Linguistics*, pages 6636–6648, 2023.
- J. Ma, T. Sun, and X. Zhang. Time highlighted multi-interest network for sequential recommendation. *Computers, Materials & Continua*, 76(3), 2023.

References iii

- S. V. Mehta, J. Gupta, Y. Tay, M. Dehghani, V. Q. Tran, J. Rao, M. Najork, E. Strubell, and D. Metzler. Dsi++: Updating transformer memory with new documents. *arXiv preprint arXiv:2212.09744*, 2022.
- D. Metzler, Y. Tay, D. Bahri, and M. Najork. Rethinking search: Making domain experts out of dilettantes. *SIGIR Forum*, 55(1):1–27, 2021.
- T. Murayama. Dataset of fake news detection and fact verification: a survey. *arXiv preprint arXiv:2111.03299*, 2021.
- U. Nadeem, N. Ziems, and S. Wu. Codedsi: Differentiable code search. *arXiv preprint arXiv:2210.00328*, 2022.
- M. Najork. Generative information retrieval (slides), 2023. URL https://docs.google.com/presentation/d/191AeVzPkh20Ly855tKDkz1uv-1pHV_9GxfntiTJPUug/.
- R. Pradeep, K. Hui, J. Gupta, A. D. Lelkes, H. Zhuang, J. Lin, D. Metzler, and V. Q. Tran. How does generative retrieval scale to millions of passages? In *Gen-IR@SIGIR 2023: The First Workshop on Generative Information Retrieval*, 2023.

References iv

- S. Rajput, N. Mehta, A. Singh, R. H. Keshavan, T. Vu, L. Heldt, L. Hong, Y. Tay, V. Q. Tran, J. Samost, et al. Recommender systems with generative retrieval. *arXiv preprint arXiv:2305.05065*, 2023.
- R. Ren, W. X. Zhao, J. Liu, H. Wu, J.-R. Wen, and H. Wang. Tome: A two-stage approach for model-based retrieval. In *Proceedings of the 61st Annual Meeting of the Association for Computational Linguistics*, pages 6102–6114, 2023.
- C. Shah and E. M. Bender. Situating search. In *Proceedings of the 2022 Conference on Human Information Interaction and Retrieval*, pages 221–232, 2022.
- W. Sun, L. Yan, Z. Chen, S. Wang, H. Zhu, P. Ren, Z. Chen, D. Yin, M. de Rijke, and Z. Ren. Learning to tokenize for generative retrieval. In *Thirty-seventh Conference on Neural Information Processing Systems*, 2023.
- Y. Tang, R. Zhang, J. Guo, J. Chen, Z. Zhu, S. Wang, D. Yin, and X. Cheng. Semantic-enhanced differentiable search index inspired by learning strategies. In *29th ACM SIGKDD Conference on Knowledge Discovery and Data Mining*, 2023a.

References v

- Y. Tang, R. Zhang, J. Guo, M. de Rijke, W. Chen, and X. Cheng. Listwise generative retrieval models via a sequential learning process. *arXiv*, 2023b. Major revision.
- Y. Tay, V. Q. Tran, M. Dehghani, J. Ni, D. Bahri, H. Mehta, Z. Qin, K. Hui, Z. Zhao, J. Gupta, T. Schuster, W. W. Cohen, and D. Metzler. Transformer memory as a differentiable search index. In *Advances in Neural Information Processing Systems*, volume 35, pages 21831–21843, 2022.
- Z. Wang, Y. Zhou, Y. Tu, and Z. Dou. Novo: Learnable and interpretable document identifiers for model-based ir. In *Proceedings of the 32nd ACM Conference on Information and Knowledge Management*, 2023.
- P. Zhang, Z. Liu, Y. Zhou, Z. Dou, and Z. Cao. Term-sets can be strong document identifiers for auto-regressive search engines. *arXiv preprint arXiv:2305.13859*, 2023.
- W. X. Zhao, K. Zhou, J. Li, T. Tang, X. Wang, Y. Hou, Y. Min, B. Zhang, J. Zhang, Z. Dong, et al. A survey of large language models. *arXiv preprint arXiv:2303.18223*, 2023.
- Y. Zhou, J. Yao, Z. Dou, L. Wu, P. Zhang, and J.-R. Wen. Ultron: An ultimate retriever on corpus with a model-based indexer. *arXiv preprint arXiv:2208.09257*, 2022.

- Y. Zhou, Z. Dou, and J.-R. Wen. Enhancing generative retrieval with reinforcement learning from relevance feedback. In *EMNLP 2023: Proceedings of the 2023 Conference on Empirical Methods in Natural Language Processing*, 2023.
- S. Zhuang, H. Ren, L. Shou, J. Pei, M. Gong, G. Zuccon, and D. Jiang. Bridging the gap between indexing and retrieval for differentiable search index with query generation. In *Gen-IR@SIGIR 2023: The First Workshop on Generative Information Retrieval*, 2023.